

ASME B16.1-2015
(Revision of ASME B16.1-2010)

Gray Iron Pipe Flanges and Flanged Fittings

Classes 25, 125, and 250

AN AMERICAN NATIONAL STANDARD



**The American Society of
Mechanical Engineers**

ASME B16.1-2015
(Revision of ASME B16.1-2010)

Gray Iron Pipe Flanges and Flanged Fittings

Classes 25, 125, and 250

AN AMERICAN NATIONAL STANDARD



**The American Society of
Mechanical Engineers**

Two Park Avenue • New York, NY • 10016 USA

Date of Issuance: December 28, 2015

The next edition of this Standard is scheduled for publication in 2020.

ASME issues written replies to inquiries concerning interpretations of technical aspects of this Standard. Periodically certain actions of the ASME B16 Committee may be published as Cases. Cases and interpretations are published on the ASME Web site under the Committee Pages at <http://cstools.asme.org/> as they are issued.

Errata to codes and standards may be posted on the ASME Web site under the Committee Pages to provide corrections to incorrectly published items, or to correct typographical or grammatical errors in codes and standards. Such errata shall be used on the date posted.

The Committee Pages can be found at <http://cstools.asme.org/>. There is an option available to automatically receive an e-mail notification when errata are posted to a particular code or standard. This option can be found on the appropriate Committee Page after selecting “Errata” in the “Publication Information” section.

ASME is the registered trademark of The American Society of Mechanical Engineers.

This code or standard was developed under procedures accredited as meeting the criteria for American National Standards. The Standards Committee that approved the code or standard was balanced to assure that individuals from competent and concerned interests have had an opportunity to participate. The proposed code or standard was made available for public review and comment that provides an opportunity for additional public input from industry, academia, regulatory agencies, and the public-at-large.

ASME does not “approve,” “rate,” or “endorse” any item, construction, proprietary device, or activity.

ASME does not take any position with respect to the validity of any patent rights asserted in connection with any items mentioned in this document, and does not undertake to insure anyone utilizing a standard against liability for infringement of any applicable letters patent, nor assumes any such liability. Users of a code or standard are expressly advised that determination of the validity of any such patent rights, and the risk of infringement of such rights, is entirely their own responsibility.

Participation by federal agency representative(s) or person(s) affiliated with industry is not to be interpreted as government or industry endorsement of this code or standard.

ASME accepts responsibility for only those interpretations of this document issued in accordance with the established ASME procedures and policies, which precludes the issuance of interpretations by individuals.

No part of this document may be reproduced in any form,
in an electronic retrieval system or otherwise,
without the prior written permission of the publisher.

The American Society of Mechanical Engineers
Two Park Avenue, New York, NY 10016-5990

Copyright © 2015 by
THE AMERICAN SOCIETY OF MECHANICAL ENGINEERS
All rights reserved
Printed in U.S.A.

CONTENTS

Foreword	iv
Committee Roster	vi
Correspondence With the B16 Committee	vii
Summary of Changes	viii
List of Changes in Record Number Order	ix
1 Scope	1
2 General	1
3 Pressure–Temperature Ratings	1
4 Size	2
5 Marking	2
6 Materials	2
7 Fitting Dimensions and Tolerances	2
8 Bolt, Nut, and Gasket Dimensions	4
9 Hydrostatic Tests	5
10 Certifications	5
Figures	
1 Method of Designating Outlets of Reducing Fittings in Specifications	6
2 Drain Connections	7
3 Method of Designating Location of Tapped Holes for Drains When Specified	8
Tables	
1 Pressure–Temperature Ratings	9
2 Class 250 Flange and Bolting Dimensions	10
3 Dimensions of Class 25 Gray Iron Flanged Fittings	12
4 Dimensions of Class 125 Gray Iron Flanged Fittings	14
5 Dimensions of Class 250 Gray Iron Flanged Fittings	19
6 Dimensions of Anchorage Bases for Straight and Reducing Class 125 Tees	24
7 Dimensions of Anchorage Bases for Straight and Reducing Class 250 Tees	26
8 Class 25 Flange and Bolting Dimensions	28
9 Class 125 Flange and Bolting Dimensions	29
10 Minimum Thread Length	30
Mandatory Appendices	
I Dimensions of Fittings in U.S. Customary Units	31
II References	57
Nonmandatory Appendix	
A Quality System Program	58

FOREWORD

In 1894, the American Society of Mechanical Engineers (ASME) adopted a standard flange template (“ASME Standard”) for low-pressure service. A “Manufacturers Standard” for pressures up to 250 psi followed in 1901. Around 1910, a group of fittings manufacturers formed an organization that was the forerunner of the present Manufacturers Standardization Society of the Valve and Fittings Industry (MSS) and undertook the design of a line of flanged fittings. A document covering this work was published in 1912.

During the years 1912–1914, a Joint Committee of the ASME and the Manufacturers Committee formulated compromise standard dimensions for pipe flanges and flanged fittings for use under saturated steam pressures of 125 psi and 250 psi pressure ranges. The Joint Committee’s report was accepted at a conference attended by representatives of ASME, the Manufacturers Committee, the U.S. government, and the National Association of Master Steam and Hot Water Fitters. ASME published this report as the “American Standard for Pipe Flanges, Fittings and Their Bolting” in 1914. In 1918, work was started on standards for 50 lb steam flanges and for 800 lb, 1,200 lb, and 3,000 lb hydraulic flanges, which were subsequently approved by this group.

In 1921, the American Engineering Standards Committee, later known as the American Standards Association (ASA), United States of America Standards Institute (USAS), and more recently, the American National Standards Institute (ANSI), organized Sectional Committee B16 to unify and further develop national standards for pipe flanges and fittings (and later for valves and gaskets). Cosponsors of the B16 Committee were ASME, MSS, and the Heating and Piping Contractors Association [now the Mechanical Contractors Association of America (MCAA)]. Work already in progress on flanges and flanged fittings was assigned to Subcommittee 1 (now Subcommittee A). Following approval by the Subcommittee, the B16 Committee, the cosponsors, and ASA, the standards were published in 1928.

In later work, Subcommittee 1 developed the 25 lb Flange and Flanged Fitting Standard (approved in 1931 as ASA B16b2), which replaced the 50 lb standard that had been originally approved in 1918. Work on the 800 lb Hydraulic Flange Standard was published as ASA B16b1 in 1931. Revision of thicknesses, tolerances, and service pressure ratings of the 125 lb and 250 lb flanges and flanged fittings led to approval and publication of ASA B16a-1939.

An American war standard entitled “Pressure Ratings for Cast Iron Flanges and Flanged Fittings, 125 lb” (ASA B16a1) was published in 1943. A complete review of the 125 lb and 250 lb standards resulted in new editions of each: ASA B16.1-1948 and ASA B16.2-1948. In 1960, editions of B16.1 and B16.2 were issued in which ratings were presented in graphic form and special requirements were added for testing flanges.

A review of all gray iron flange and flanged fittings standards initiated in 1962 resulted in the withdrawal of B16.16, “300 lb Refrigerant Flanges and Flanged Fittings” and the combining of the remaining standard into a single document, with B16.1 and B16.2 coming together as USAS B16.1-1967. In this edition, the presentation of ratings was restored to tabular form.

The increasing use of higher grades of gray iron necessitated the establishment of a second set of ratings for the smaller sizes. A revised edition published as ANSI B16.1-1975 incorporated these new ratings along with metric (SI) equivalents for dimensions and minor corrections to the 1967 edition text.

In 1982, American National Standards Committee B16 was recognized as an ASME Committee operating under procedures accredited by ANSI. Following approval by the ASME B16 Subcommittee A and B16 Committee, ANSI approved ASME/ANSI B16.1-1989 on March 8, 1989. Changes included revised marking requirements, revised bolt length increments ($\frac{1}{2}$ in. rather than $\frac{1}{4}$ in.), elimination of metric equivalents, a correction of the Class 800 flange raised-face height to 0.25 in. from the 0.06 in. shown previously, and editorial changes to the text.

In the 1998 edition of ASME B16.1, Reference Standards were updated, a Quality System Program Annex was added, Class 800 was deleted, and several editorial revisions were made.

Following approval by ASME B16 Subcommittee B and B16 Main Committee, ANSI approved ASME B16.1-1998 on November 20, 1998.

Work was started in 1999 to revise the standard to include metric units as the primary reference units while maintaining U.S. Customary units in either parenthetical or separate forms. Following approval of the Standard Committee and ASME, approval as an American National Standard was given by ANSI on July 8, 2005, with the new designation ASME B16.1-2005.

In the 2010 edition of ASME B16.1, the Scope was separated into its own paragraph with all following paragraphs renumbered accordingly, references were updated, and several editorial revisions were made. Following approval of the B16 Standards Committee, approval as an American National Standard was given by ANSI on November 17, 2010.

In this 2015 Edition, provisions have been made to provide bolt hole tolerances that are appropriate to this Standard. Following the approval by the ASME B16 Standards Committee, approval as an American National Standard was given by ANSI on July 29, 2015, with the new designation ASME B16.1-2015.

All requests for interpretation or suggestions for revision should be sent to the Administrative Secretary B16, The American Society of Mechanical Engineers, Two Park Avenue, New York, NY 10016-5990.

ASME B16 COMMITTEE

Standardization of Valves, Flanges, Fittings, Gaskets, and Valve Actuators

(The following is the roster of the Committee at the time of approval of this Standard.)

STANDARDS COMMITTEE OFFICERS

R. Bojarczuk, *Chair*
C. E. Davila, *Vice Chair*
C. E. O'Brien, *Secretary*

STANDARDS COMMITTEE PERSONNEL

A. Appleton , Alloy Stainless Products Co., Inc.	T. A. McMahon , Emerson Process Management
R. W. Barnes , Anric Enterprises, Inc.	M. L. Nayyar , NICE
K. Barron , Ward Manufacturing	C. E. O'Brien , The American Society of Mechanical Engineers
W. B. Bedesem , Consultant	W. H. Patrick , The Dow Chemical Co.
R. Bojarczuk , Exxon Mobil Research and Engineering Co.	D. W. Raho , Consultant
A. M. Cheta , Shell Exploration and Production Co.	R. A. Schmidt , Canadoil
M. A. Clark , Nibco, Inc.	H. R. Sonderegger , Fluoroseal Valves USA
G. A. Cuccio , Capitol Manufacturing Co.	W. M. Stephan , Flexitallic LP
C. E. Davila , Crane Energy	F. R. Volgstadt , Volgstadt and Associates, Inc.
D. R. Frikken , Becht Engineering Co.	D. A. Williams , Southern Co. Generation
R. B. Hai , RBH Associates	F. Feng , <i>Delegate</i> , China Productivity Center for Machinery
K. A. Hettler , U.S. Coast Guard	P. V. Craig , <i>Contributing Member</i> , Jomar Group
G. A. Jolly , Flowserve/Gestra, USA	B. G. Fabian , <i>Contributing Member</i> , Pennsylvania Machine Works
M. Katcher , Haynes International	D. F. Reid , <i>Contributing Member</i> , VSP Technologies
	C. Stout , <i>Contributing Member</i> , Mueller Industries

SUBCOMMITTEE B — THREADED FITTINGS (EXCEPT STEEL), FLANGES, AND FLANGED FITTINGS (B16)

K. Barron , <i>Chair</i> , Ward Manufacturing	D. Hunt, Jr. , Fastenal
G. T. Walden , <i>Vice Chair</i> , Wolseley	W. H. LeVan , Cast Iron Soil Pipe Institute
C. R. Ramcharran , <i>Secretary</i> , The American Society of Mechanical Engineers	J. K. Schultz , Conine Manufacturing Co., Inc.
W. Bliss , Tyler Pipe Co.	G. L. Simmons , Charlotte Pipe and Foundry
M. A. Clark , Nibco, Inc.	A. A. Knapp , <i>Contributing Member</i> , A. Knapp and Associates
J. R. Holstrom , Val-Matic Valve and Manufacturing Co.	P. I. McGrath, Jr. , <i>Contributing Member</i> , Consultant

CORRESPONDENCE WITH THE B16 COMMITTEE

General. ASME Standards are developed and maintained with the intent to represent the consensus of concerned interests. As such, users of this Standard may interact with the Committee by requesting interpretations, proposing revisions or a Case, and attending Committee meetings. Correspondence should be addressed to:

Secretary, B16 Standards Committee
The American Society of Mechanical Engineers
Two Park Avenue
New York, NY 10016-5990

As an alternative, inquiries may be submitted via e-mail to: SecretaryB16@asme.org.

Proposing Revisions. Revisions are made periodically to the Standard to incorporate changes that appear necessary or desirable, as demonstrated by the experience gained from the application of the Standard. Approved revisions will be published periodically.

The Committee welcomes proposals for revisions to this Standard. Such proposals should be as specific as possible, citing the paragraph number(s), the proposed wording, and a detailed description of the reasons for the proposal, including any pertinent documentation.

Proposing a Case. Cases may be issued for the purpose of providing alternative rules when justified, to permit early implementation of an approved revision when the need is urgent, or to provide rules not covered by existing provisions. Cases are effective immediately upon ASME approval and shall be posted on the ASME Committee Web page.

Requests for Cases shall provide a Statement of Need and Background Information. The request should identify the Standard and the paragraph, figure, or table number(s), and be written as a Question and Reply in the same format as existing Cases. Requests for Cases should also indicate the applicable edition(s) of the Standard to which the proposed Case applies.

Interpretations. Upon request, the B16 Committee will render an interpretation of any requirement of the Standard. Interpretations can only be rendered in response to a written request sent to the Secretary of the B16 Standards Committee.

The request for interpretation should be clear and unambiguous. It is further recommended that the inquirer submit his/her request in the following format:

Subject: Cite the applicable paragraph number(s) and the topic of the inquiry.
Edition: Cite the applicable edition of the Standard for which the interpretation is being requested.
Question: Phrase the question as a request for an interpretation of a specific requirement suitable for general understanding and use, not as a request for an approval of a proprietary design or situation. The inquirer may also include any plans or drawings that are necessary to explain the question; however, they should not contain proprietary names or information.

Requests that are not in this format may be rewritten in the appropriate format by the Committee prior to being answered, which may inadvertently change the intent of the original request.

ASME procedures provide for reconsideration of any interpretation when or if additional information that might affect an interpretation is available. Further, persons aggrieved by an interpretation may appeal to the cognizant ASME Committee or Subcommittee. ASME does not "approve," "certify," "rate," or "endorse" any item, construction, proprietary device, or activity.

Attending Committee Meetings. The B16 Standards Committee regularly holds meetings and/or telephone conferences that are open to the public. Persons wishing to attend any meeting and/or telephone conference should contact the Secretary of the B16 Standards Committee.

ASME B16.1-2015 SUMMARY OF CHANGES

Following approval by the B16 Committee and ASME, and after public review, ASME B16.1-2015 was approved by the American National Standards Institute on July 29, 2015.

ASME B16.1-2015 includes editorial changes, revisions, and corrections, which are identified by a margin designator, **(15)**, placed next to the affected area.

<i>Page</i>	<i>Location</i>	<i>Change</i>
1	2.3	Editorially revised
1	2.5	Editorially revised
4	7.6	New para. 7.6.2 added and subsequent paragraphs redesignated (14-2394)
	8.1	Revised in its entirety (14-2394)
	8.2	Revised
29	Table 9	NPS 14, 54, 60, and 72 corrected by errata (13-1932, 14-1542)
58	Mandatory Appendix II	References updated (10-1036)

LIST OF CHANGES IN RECORD NUMBER ORDER

Record Number	Change
10-1036	Updated referenced standards within B16.1 to reflect the latest edition.
13-1932	In Table 9, NPS 14, 54, 60, and 72 for "Diameter of Bolts" corrected by errata.
14-1542	In Table 9, NPS 14 for "Minimum Thickness of Flange" corrected by errata.
14-2394	Added new paras. 7.6.2 and 8.1(a), which provide bolt hole tolerances that are appropriate for addition to B16.1. Revising this Standard to require bolt hole tolerances eliminates the issues of oversized bolt holes and high compression loads under the bolt heads. Paragraphs 7.6.2 through 7.6.5 were redesignated as 7.6.3 through 7.6.6. Paragraphs 8.1(a) and (b) were redesignated as 8.1(b) and (c). Deleted previous para. 8.1(c).

INTENTIONALLY LEFT BLANK

GRAY IRON PIPE FLANGES AND FLANGED FITTINGS

Classes 25, 125, and 250

1 SCOPE

This Standard covers Classes 25, 125, and 250 Gray Iron Pipe Flanges and Flanged Fittings. It includes

- (a) pressure–temperature ratings
- (b) sizes and method of designating openings of reducing fittings
- (c) marking
- (d) materials
- (e) dimensions and tolerances
- (f) bolting and gaskets
- (g) pressure testing

2 GENERAL

2.1 References

Standards and specifications adopted by reference in this Standard are shown in Mandatory Appendix II, which is part of this Standard. It is not considered practical to identify the specific edition of each referenced standard and specification in the text, when referenced. Instead, the specific editions of the referenced standards and specifications are listed in Mandatory Appendix II.

2.2 Quality Systems

Requirements relating to the product manufacturer's Quality System Programs are described in Nonmandatory Appendix A.

(15) 2.3 Relevant Units

This Standard states values in both SI and U.S. Customary units. As an exception, diameter of bolts and flange bolt holes are expressed in inch units only. These systems of units are to be regarded separately as standard. Within the text, the U.S. Customary units are shown in parentheses or in separate tables that appear in Mandatory Appendix I. The values stated in each system are not exact equivalents; therefore, it is required that each system of units be used independently of the other. Except for diameter of bolts and flange bolt holes, combining values from the two systems constitutes non-conformance with the Standard.

2.4 Service Conditions

Criteria for selection of materials suitable for particular fluid service are not within the scope of this Standard.

2.5 Convention

(15)

For determining conformance with this Standard, the convention for fixing significant digits where limits (maximum and minimum values) are specified shall be as defined in ASTM E29. This requires that an observed or calculated value be rounded off to the nearest unit in the last right-hand digit used for expressing the limit. Decimal values and tolerances do not imply a particular method of measurement.

2.6 Denotation

2.6.1 Pressure Rating Designation. Class, followed by a dimensionless number, is the designation for pressure–temperature ratings as follows:

Class	25	125	250
-------	----	-----	-----

2.6.2 Size. NPS, followed by a dimensionless number, is the designation for nominal flange or flange fitting size. NPS is related to the reference nominal diameter, DN, used in international standards. The relationship is, typically, as follows:

NPS	DN
1	25
1¼	32
1½	40
2	50
2½	65
3	80
3½	...
4	100

GENERAL NOTE: For $NPS \geq 4$, the related $DN = 25 \times (NPS)$.

3 PRESSURE–TEMPERATURE RATINGS

3.1 General

Pressure–temperature ratings are maximum allowable working pressures in bar units at the temperature in degrees Celsius shown in Table 1 for the applicable material and class designation. Table I-1 of Mandatory Appendix I lists pressure–temperature ratings using psi units for pressure at the temperature in degrees Fahrenheit. For intermediate temperatures, linear interpolation is permitted. Interpolation between class designations is not permitted.

3.2 Flanged Joints

A flanged joint is composed of independent interrelated components; the flanges, the gasket, and the bolting, that are assembled manually. Proper controls must be exercised in the selection and application for these elements to attain a joint that has acceptable leak tightness. Special techniques, such as controlled bolt tightening described in ASME PCC-1, may be used to achieve a tight joint in service.

3.3 Rating Temperature

Temperatures shown for the corresponding pressure rating shall be the material temperature of the pressure-retaining structure. It may be assumed that the material temperature is the same as the fluid temperature. Use of a pressure rating at a material temperature other than that of the contained fluid is the responsibility of the user and subject to the requirements of any applicable code or regulation.

3.4 Low-Temperature Ratings

Pressure ratings for temperatures below -29°C (-20°F) should be determined in accordance with low-temperature properties of gray iron (ASTM A126) as governed by applicable code or regulation.

3.5 Ductility

Gray Iron has little ductility, therefore, the resistance of these flanges and flanged fittings to excessive forces and suddenly applied loads is significantly less than for more ductile materials such as steel. The following precautions are recommended:

(a) These flanges and flanged fittings should not be used where suddenly applied loads such as rapid pressure fluctuation may occur.

(b) Alignment of flange faces is essential along with control of assembly bolt torque so as not to over-stress the gray iron flanges. Care should also be exercised to ensure that piping loads transmitted to gray iron flanges are controlled.

4 SIZE

4.1 Nominal Pipe Size

As applied in this Standard, the use of the phrase "nominal pipe size" or the designation NPS followed by a dimensionless number is for the purpose of identifying the end connection of piping, flanges, or flanged fittings. The number is not necessarily the same as the flange or flanged fitting inside diameter.

4.2 Reducing Fittings

Reducing fittings shall be designated by NPS for the openings in the sequence as indicated in the sketches of Fig. 1.

5 MARKING

5.1 Fittings

The manufacturer's name or trademark and numerals as shown below for each pressure rating class designation shall be cast on the exterior surface of all fittings.

Class	NPS	Numeral
25	All	25
125	$1 \leq \text{NPS} \leq 12$	125
	$14 \leq \text{NPS} \leq 24$	100
	$30 \leq \text{NPS} \leq 48$	50
250	$1 \leq \text{NPS} < 12$	250
	$14 \leq \text{NPS} \leq 24$	200
	$30 \leq \text{NPS} \leq 48$	100

5.2 Flanges

The manufacturer's name or trademark shall be cast on all loose flanges. In addition, the numeral 25 shall be cast on Class 25 flanges. Numerals for other classes designations shall be cast on loose flanges in addition to the requirements of para. 5.3.

5.3 Material Class

In those sizes and pressure-rating class designations, where ASTM A 126, both Classes A and B iron, can be used, see para. 6.1, letter A or B shall be cast on both flanges and fittings in the proximity of the numerals. Flanges and fittings with no A or B Class iron marking shall be considered as Class A iron for rating purposes.

6 MATERIALS

6.1 Castings

Castings shall meet the requirements of ASTM A126 for both flanges and flanged fittings, as follows:

Class	NPS	Class of Iron ASTM A126
25	All	A
125	$1 \leq \text{NPS} \leq 12$	A or B
	$14 \leq \text{NPS}$	B
250	$1 \leq \text{NPS} \leq 12$	A or B
	$14 \leq \text{NPS}$	B

6.2 Bolting

ASTM A307 Grade B bolting material is recommended for gray iron flange assembly. Where gray iron flanges are bolted to steel flanges, see ASME B16.5 for bolting limitations.

7 FITTING DIMENSIONS AND TOLERANCES

7.1 Wall Thickness

It is recognized that some variations are absolutely unavoidable in the making of patterns and castings.

Equipment shall be designed to produce wall thicknesses given in the tables. Wall thickness at no point shall be less than 87.5% of the thickness given in the tables.

7.2 Facing

(a) Classes 25 and 125 gray iron flanges and flanged fittings shall be flat faced (i.e., without projection or raised face) and finished in accordance with MSS SP-6.

(b) Class 250 flanges and flanged fittings shall have a 2 mm (0.06 in.) raised face of the diameters given in Table 2 and finished in accordance with MSS SP-6. The raised face is included in the minimum flange thickness and center-to-face dimension.

7.3 Center-to-Face Dimensions

7.3.1 Side Outlet Fittings. Side outlet elbows, side outlet tees, and side outlet crosses shall have all openings on intersecting centerlines. Long-radius elbows with side outlet shall have the side outlet on the radial centerline of the elbow.

7.3.2 Elbows

(a) The center-to-face dimensions for straight-size 90-deg elbows, 90-deg long-radius elbows, 45-deg elbows, side-outlet 90-deg elbows, and double-branch elbows are shown in Tables 3, 4, and 5.

(b) Reducing 90-deg elbows, reducing 90-deg long-radius elbows, reducing side-outlet 90-deg elbows, and reducing double-branch elbows shall have the same center-to-face dimensions as straight-size fittings shown in Tables 3, 4, and 5 corresponding to the size of the largest opening.

(c) For 90-deg long-radius elbows with side outlet, the center-to-face dimensions of the side outlet shall be the same as dimension *A* in Tables 3, 4, and 5 for a straight-size 90-deg elbow corresponding to the size of the largest opening.

(d) Special-degree elbows ranging from 1 deg to 45 deg, inclusive, shall have the same center-to-face dimensions as those for 45-deg elbows; those over 45 deg and up to 90 deg, inclusive, shall have the same center-to-face dimensions as those for 90-deg elbows. The angle designation of an elbow is the angle between the flange faces.

7.3.3 Tees, Crosses, and Laterals

(a) The center-to-face dimensions for straight-size tees and crosses, with or without side outlet, and laterals are shown in Tables 3, 4, and 5.

(b) Reducing tees and reducing crosses, with or without side outlet, and reducing laterals, NPS 16 and smaller, shall have the same center-to-face dimensions as straight-size fittings shown in Tables 3, 4, and 5 corresponding to the size of the largest opening. For NPS 18 and larger, if the outlet of a reducing tee; the branch of a reducing lateral; or the largest outlet of a reducing

side outlet tee, reducing cross, and reducing side outlet cross is the same size or smaller than given in Tables 3, 4, and 5 (short body pattern), the center-to-face dimensions shown in these Tables shall be used. If a branch or any outlet is larger than shown in Tables 3, 4, and 5, the center-to-face dimensions shall be the same as for the straight-size fitting shown in Tables 3, 4, and 5 corresponding to the size of the largest opening. Tees, crosses, and laterals, reducing on the run only, shall have the same center-to-face dimensions as straight-size fittings shown in Tables 3, 4, and 5 corresponding to the size of the largest opening.

(c) Tees reducing on both runs are generally known as bull-head tees and have the same center-to-face dimensions as straight-size fittings corresponding to the size of the outlet.

7.3.4 True Y's. Center-to-face dimensions for straight-size true Y's are shown in Tables 4 and 5. Reducing sizes are considered special and should be made to suit conditions.

7.3.5 Reducers and Eccentric Reducers. The face-to-face dimensions for all reductions of reducers and eccentric reducers shall be the same as given in Tables 4 and 5 for the largest opening.

7.4 Center-to-Face Tolerances

The following tolerances shall be permitted on all center-to-contact surface dimensions of fittings: Tolerances for contact surface-to-contact surface dimensions shall be twice those given below. The largest opening in the fitting governs the tolerance to be applied to all openings.

NPS	Tolerance	
	mm	in.
≤10	±1.0	±0.03
≥12	±1.5	±0.06

7.5 Threaded Flanges

7.5.1 General. Flanges shall have a Standard Taper Pipe Thread in accordance with ASME B1.20.1. The thread shall be concentric with the axis of the flange, and variations in alignment shall not exceed 5.00 mm/m (0.06 in./ft).

7.5.2 Class 125. Threads shall be countersunk a distance not less than one-half of the pitch of the thread at an angle approximately 45 deg with the axis of the thread, for the purpose of easy entrance in making the joint and protection of the threads. Countersinking shall be concentric with the threads. The length of the threads shall be measured to include the countersink.

7.5.3 Class 250. Hub may be recessed. When not recessed, threads shall be countersunk a distance not less than one-half of the pitch of the thread at an angle approximately 45 deg with the axis of the thread at the back of the flange. If hub is recessed, threads shall be 45 deg countersunk to diameter of recess. The purpose is for easier entrance in making a joint and for the protection of the threads. Countersinking shall be concentric with the threads. The length of threads shall be measured to include the countersink.

(15) 7.6 Flange Bolt Holes

7.6.1 Flange Bolt Holes. Flange bolt holes shall be in accordance with the dimensions shown in Tables 2, 8, and 9. Pairs of bolt holes shall straddle the centerline.

7.6.2 Flange Bolt Hole Tolerance. Tolerances for bolt hole sizes $\frac{5}{8}$ through $\frac{7}{8}$ shall be -0.000 in. (0.00 mm), $+0.015$ in. (0.38 mm) and for bolt holes sizes 1 through $1\frac{1}{2}$ shall be -0.000 in. (0.00 mm), $+0.031$ in. (0.79 mm).

7.6.3 Bolt Circle Diameter. The required tolerance for a bolt circle diameter is ± 1.5 mm (± 0.06 in.).

7.6.4 Bolt Hole to Bolt Hole. The required tolerance for the center-to-center of adjacent bolt hole is ± 0.8 mm (± 0.03 in.).

7.6.5 Bolt Circle Concentricity. The required tolerance for concentricity between the flange bolt circle diameter and machined facing diameters are as follows:

NPS $\leq 2\frac{1}{2}$	0.8 mm (0.03 in.)
NPS ≤ 48	1.5 mm (0.06 in.)

7.6.6 Tolerance. Tolerances for sizes larger than NPS 48 shall be as agreed between the Manufacturer and purchaser.

7.7 Spot Facing

All flanges and flanged fittings covered by this Standard shall have bearing surfaces for bolting that are parallel to the flange face within 3 deg. Any back facing or spot facing required to accomplish parallelism shall not reduce the flange thickness Q below the dimensions given in Tables 2 through 5, 8, and 9. Flange thickness at any point within the spot face area, as defined in MSS SP-9, shall not exceed the required minimum thickness by more than the following amounts:

NPS	Excess Thickness, mm (in.)
$2 \leq \text{NPS} \leq 12$	3.0 (0.12)
$14 \leq \text{NPS} \leq 24$	4.5 (0.18)
$30 \leq \text{NPS} \leq 96$	6.5 (0.25)

When required, all spot facing shall be done in accordance with MSS SP-9. Sharp corners shall be avoided in back facing.

7.8 Crosses and Lateral Reinforcement

Crosses and laterals (Y-branches) both straight and reducing shall be reinforced where necessary to compensate for the inherent weakness in the shape of these fittings.

7.9 Drain Connections

7.9.1 Threaded Connections. Holes may be drilled and tapped in the wall of fittings if the metal thickness is sufficient to provide the effective length of thread as shown in Fig. 2 and as specified in Table 10. Where thread length is insufficient due to metal thickness or size of tapping is such that reinforcement of opening is necessary, an integral boss should be added. In no case shall the effective length of thread A be less than that shown in Table 10. These lengths are equal to the effective thread lengths as shown in ASME B1.20.1.

7.9.2 Location Designation. The method of designating the locations of the tapped holes for drains is shown in Fig. 3. Each location is designated by a letter so that desired locations for the various types of fittings may be definitely specified without the use of further sketches or description. For further tapping details, see MSS SP-45.

8 BOLT, NUT, AND GASKET DIMENSIONS

8.1 Bolting

(15)

(a) All bolting materials shall have square, heavy hex, or hex heads and square, heavy hex, or hex nuts with full flat bearing faces as specified in ASME B18.2.1 for bolts and ASME B18.2.2 for nuts. Threads shall be UNC or UN8 and have a thread fit class of 2A for bolts and 2B for nuts. Washer faced bolts or washer faced nuts are prohibited.

(b) Carbon steel bolts 1 in. and smaller shall have square heads (ASME B18.2.1) or heavy hex heads (ASME B18.2.1) and shall have square or heavy hex nuts (ASME B18.2.2).

(c) Carbon steel bolts $1\frac{1}{8}$ in. and larger shall have square heads (ASME B18.2.1), hex heads (ASME B18.2.1), or heavy hex heads (ASME B18.2.1) and shall have hex nuts (ASME B18.2.2) or heavy hex nuts (ASME B18.2.2) or square nuts (ASME B18.2.2). For bolt sizes $1\frac{1}{2}$ in. and larger, stud bolts with a nut on each end are recommended.

8.2 Gaskets

(15)

It is recommended that flat ring gaskets be in accordance with dimensions given in ASME B16.21 for non-metallic gaskets for pipe flanges. Flanges of Class A iron should not be used with gaskets having a gasket factor ("M" as defined in ASME Section VIII, Rules for Construction of Pressure Vessels, Division 1, Mandatory Appendix 2) greater than 2.75.

9 HYDROSTATIC TESTS

(a) Pressure testing is not required unless specified by the user.

(b) *Fittings.* Fittings shall be capable of withstanding, without showing leaks, the hydrostatic test pressures listed in Table 1 for the material and maximum allowable working pressure of the item tested. These test pressures are 1.5 times the cold working pressure rate rounded to the next higher 0.5 bar (12 psi) in Table 1.

(c) *Flanges.* Flanges integral with or attached to equipment may be hydrostatically tested by the purchaser at his responsibility at pressures higher than specified herein.

10 CERTIFICATIONS

The manufacturer shall be able to certify that products are in conformance with the requirements of this Standard when required by the purchase order.

Fig. 1 Method of Designating Outlets of Reducing Fittings in Specifications

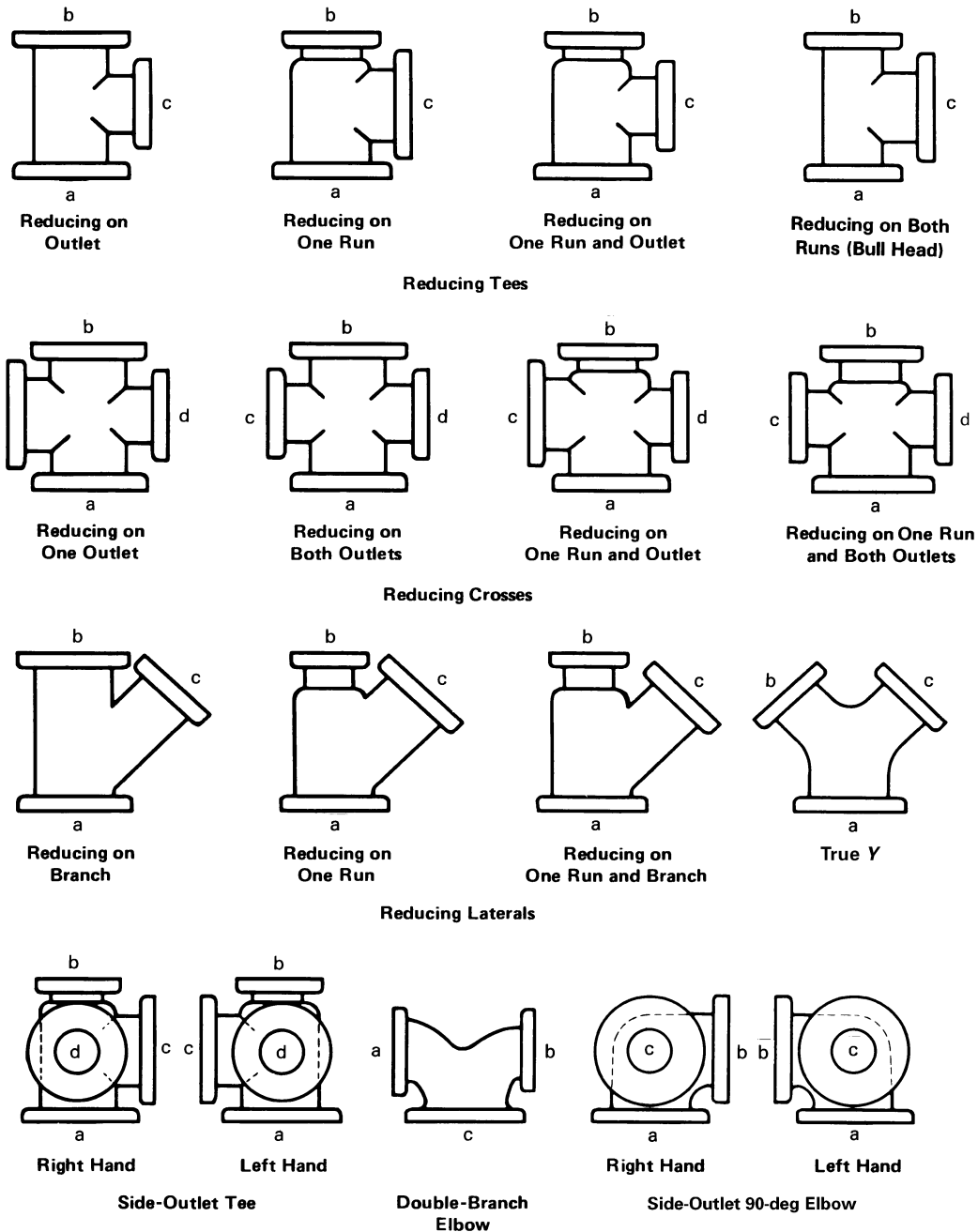

GENERAL NOTES:

- (a) The largest opening establishes the basic size of a reducing fitting. The largest opening is named first, except for bull-head tees, which are reducing on both runs, and double-branch elbows where both branches are reducing; the outlet is the largest opening and named last in both cases.
- (b) In designating the openings of reducing fittings, they should be read in the order indicated by the sequence of the letters a, b, c, and d. In designating the outlets of side-outlet reducing fittings, the side outlet is named last; and in the case of the cross (which is not shown), the side outlet is designated by the letter e.

Fig. 2 Drain Connections

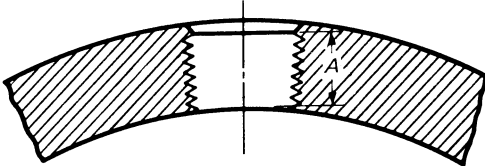
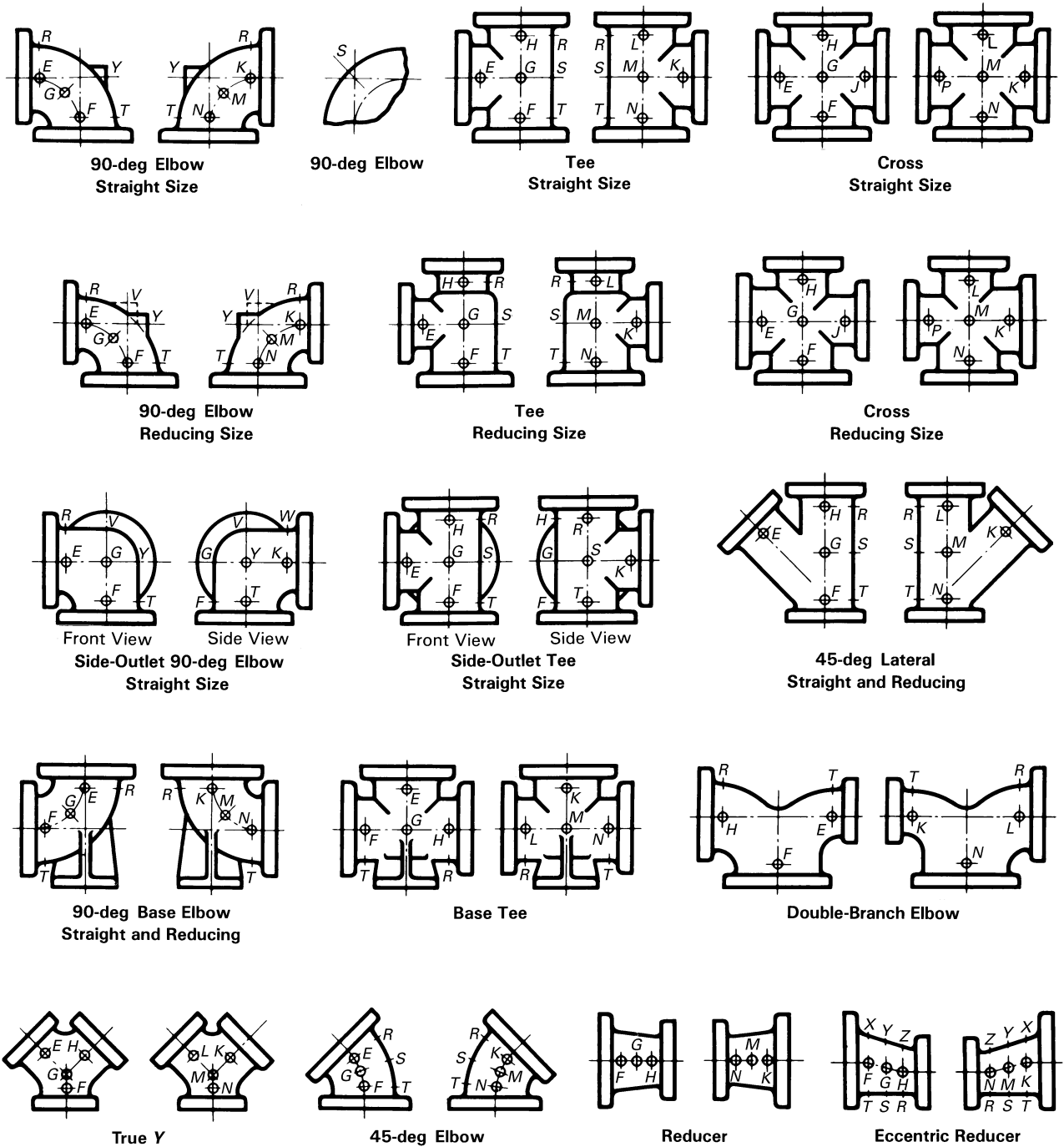

Fig. 3 Method of Designating Location of Tapped Holes for Drains When Specified



GENERAL NOTE: The above sketches show two views of the same fitting and represent fittings with symmetrical shapes, with the exception of the side-outlet elbow and the side-outlet tee (straight sizes).

Table 1 Pressure–Temperature Ratings

Temperature, °C	Class 25 [Note (1)] ASTM A126 Class A		Class 125 ASTM A126				Class 250 [Note (2)] ASTM A126			
			Class A	Class B			Class A	Class B		
	NPS 4–36	NPS 42–96	NPS 1–12	NPS 1–12	NPS 14–24	NPS 30–48	NPS 1–12	NPS 1–12	NPS 14–24	NPS 30–48
–29 to 65	3.1	1.7	12.1	13.8	10.3	10.3	27.6	34.5	20.7	20.7
80	2.9	1.7	11.6	13.3	9.8	9.1	26.5	33.0	20.0	18.9
100	2.6	1.7	11.0	12.7	9.2	7.5	25.0	30.9	19.0	16.4
120	2.1	1.7	10.4	12.1	8.6	5.8	23.5	28.8	18.0	13.9
135	1.7	1.7
140	9.8	11.5	8.0	4.2	22.1	26.7	17.0	11.5
149	3.4
160	9.2	10.8	7.4	...	20.6	24.6	16.1	9.0
178 (3)	8.6	...	6.9	6.9
180	10.2	19.2	22.5	15.1	...
200	9.6	17.8	20.5	14.2	...
208 (4)	17.2	...	13.8	...
220	9.0	18.5
232	8.6	17.2
Hydrostatic Shell Test Pressures (Bar) [Note (5)]										
38	4.8	2.7	18.3	20.7	15.5	15.5	41.4	51.8	31.0	31.0

GENERAL NOTE: Pressure is in bar.

NOTES:

- (1) When Class 25 flange or flange fittings are used for gaseous service, the maximum pressure shall be limited to 1.7 bar.
- (2) When Class 250 is used for liquid service, the tabulated pressure shall be used. Class 250: When used for liquid service the tabulated pressure–temperature ratings in sizes NPS 14 and larger are applicable to Class 250 flanges only and not to Class 250 fittings.
- (3) 178°C to reflect the temperature of saturated steam at 8.6 bar.
- (4) 208°C to reflect the temperature of saturated steam at 17.2 bar.
- (5) See section 9.

Table 2 Class 250 Flange and Bolting Dimensions

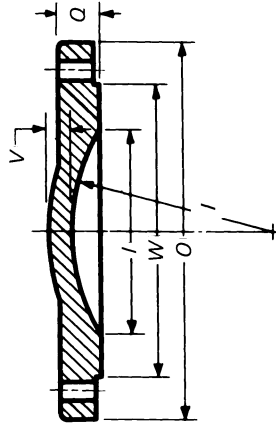

**NPS 10 and Larger
Blind Flange**

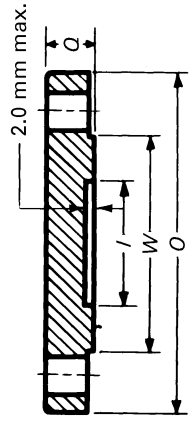

**NPS 8 and Smaller
Blind Flange**

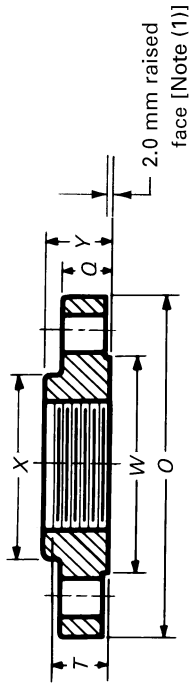

NPS	Flanges		Blind Flanges [Note (2)]		Hubs		Bolt Holes		Bolting [Note (6)]		Length of Stud Bolts [Note (8)]	
	Diameter of Flange, O	Minimum Thickness of Flange, Q	Diameter of Port, I	Wall Thickness, V [Note (3)]	Minimum Diameter of Hub, X	Minimum Length Through Hub, Y	Diameter of Bolt Circle	Diameter of Bolts [Note (5)]	Number of Bolts	Diameter of Bolts [Note (7)]		Length of Bolts [Note (8)]
1	125	17.5	25	...	52	22	89	3/4	4	5/8	64	...
1 1/4	135	19.0	32	...	64	25	98	3/4	4	5/8	64	...
1 1/2	155	20.6	38	...	70	29	114	7/8	4	3/4	70	...
2	165	22.2	51	...	84	32	127	3/4	8	5/8	70	...
2 1/2	190	25.4	64	...	100	37	149	7/8	8	3/4	83	...
3	210	28.6	76	...	118	40	168	7/8	8	3/4	89	...
3 1/2	230	30.2	89	...	133	41	184	7/8	8	3/4	89	...
4	255	31.8	102	...	146	44	200	7/8	8	3/4	95	...
5	280	34.9	127	...	178	48	235	7/8	8	3/4	102	...
6	320	36.5	152	...	206	49	270	7/8	12	3/4	102	...
8	380	41.3	203	...	260	56	330	1 1/8	12	7/8	114	...
10	445	47.6	254	23.8	321	60	387	1 1/4	16	1	131	...
12	520	50.8	305	25.4	375	65	451	1 1/4	16	1 1/8	140	...
14	585	54.0	337	28.6	413	68	514	1 3/8	20	1 1/8	152	...
16	650	57.2	387	31.8	467	73	572	1 3/8	20	1 1/4	159	...

Table 2 Class 250 Flange and Bolting Dimensions (Cont'd)

NPS	Flanges		Blind Flanges [Note (3)]			Hubs		Bolt Holes			Bolting [Note (7)]			
	Diameter of Flange, O	Minimum Thickness of Flange, Q	Diameter of Raised Face, W	Diameter of Port, I	Wall Thickness, V	Minimum Diameter of Hub, X	Minimum Length Through Hub, Y	Minimum Length of Threads, T	Diameter of Bolt Circle [Note (6)]	Diameter of Bolts [Note (6)]	Number of Bolts	Diameter of Bolts [Note (8)]	Length of Bolts [Note (9)]	Length of Stud Bolts [Note (9)]
18	710	60.3	592	432	34.9	629	$1\frac{3}{8}$	24	$1\frac{1}{4}$	165	...
20	775	63.5	649	483	38.1	686	$1\frac{3}{8}$	24	$1\frac{1}{4}$	172	...
24	915	69.8	770	584	41.3	813	$1\frac{5}{8}$	24	$1\frac{1}{2}$	191	241
30	1090	76.2	945	737	50.8	997	2	28	$1\frac{3}{4}$	216	268
36 (10)	1270	85.7	1110	1168	$2\frac{1}{4}$	32	2	241	298
42 (10)	1450	93.7	1281	1340	$2\frac{1}{4}$	36	2	254	318
48 (10)	1650	101.6	1484	1543	$2\frac{1}{4}$	40	2	273	330

GENERAL NOTE: Dimensions are in millimeters.

NOTES:

- (1) Diameter of raised face has tolerance of ± 0.8 mm.
- (2) For facing, see para. 7.2(b).
- (3) All blind flanges for NPS 10 and larger must be dished with inside radius equal to the port diameter.
- (4) For wall thickness tolerances, see para. 7.1.
- (5) For thread of threaded flanges, see paras. 7.5.1 and 7.5.3.
- (6) For flange bolt holes, see para. 7.6.
- (7) For bolts and nuts, see para. 8.1.
- (8) For spot facing, see para. 7.7.
- (9) When bolting to steel flanges, longer bolts or studs shall be used.
- (10) NPS 36-48 are not produced and used in sufficient quantities to warrant standardization; however, the flange dimensions are included for convenience where special fittings larger than NPS 30 are required. When these fittings are made, the body structure should be designed to be the equivalent of the flanges in service pressure fittings.

Table 3 Dimensions of Class 25 Gray Iron Flanged Fittings

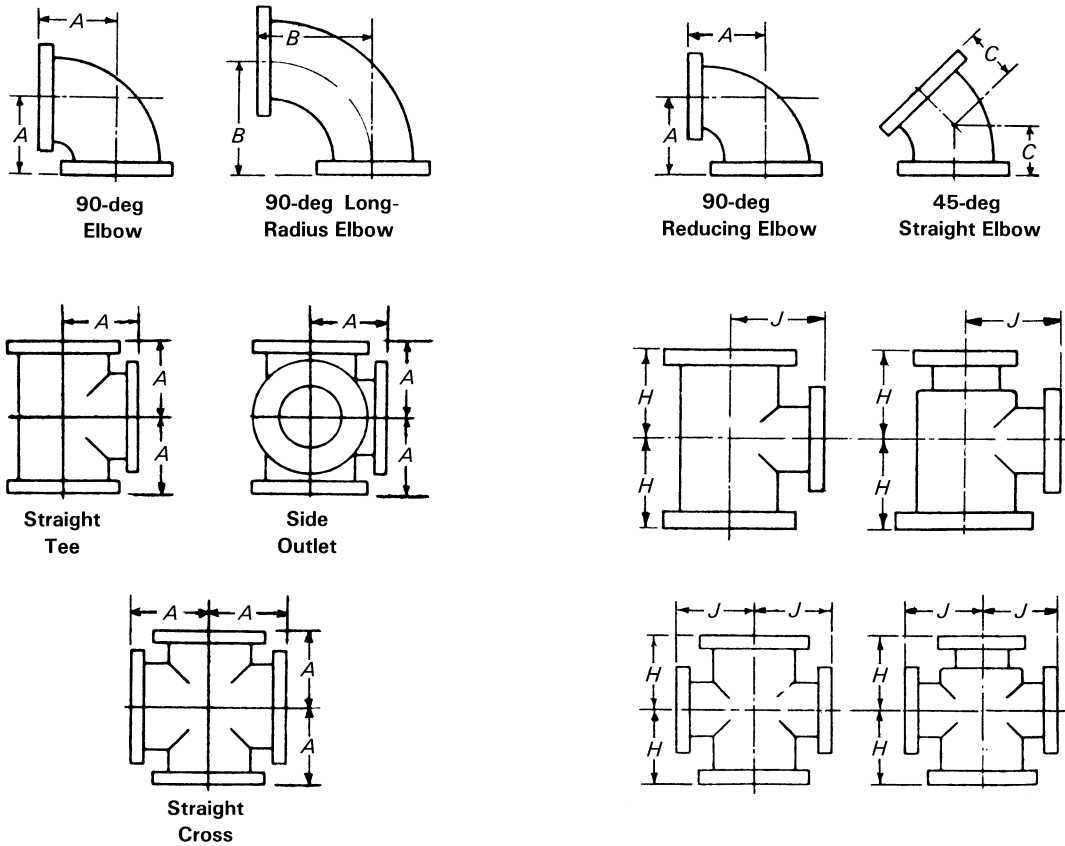

Straight Fittings

Reducing Fittings

NPS	General				Straight Size [Note (5)]			Reducing Tees and Crosses (Short-Body Pattern) [Notes (9)–(11)]		
	Diameter of Flange	Minimum Thickness of Flange	Wall Thickness of Body [Note (1)]	Inside Diameter of Fitting	Center-to-Face Elbow, Tee, and Cross, A [Notes (2)–(4)]	Center-to-Face Long Radius Elbow, B	Center-to-Face 45 deg Elbow, C [Note (6)]	NPS Size of Outlet and Smaller [Notes (7) and (8)]	Center-to-Face Run, H [Note (5)]	Center-to-Face Outlet, J [Note (5)]
4	229	19.0	11	102	165	229	102			
5	254	19.0	11	127	191	260	114			
6	279	19.0	11	152	203	292	127			
8	343	19.0	12	203	229	356	140			
10	406	22.2	13	254	279	419	165			
12	483	25.4	14	305	305	483	191			
14	533	28.6	15	356	356	546	191			
16	597	28.6	15	406	381	610	203			
18	645	31.8	16	457	419	673	216			
20	698	31.8	17	508	457	737	241			
24	813	34.9	19	610	559	864	279			
30	984	38.1	22	762	635	1054	381			
36	1168	41.3	25	914	711	1245	457			
42	1346	44.5	28	1067	787	1435	533			
48	1511	50.8	32	1219	864	1626	610			
54	1683	57.2	34	1372	991	1816	686	36	737	940
60	1854	57.2	35	1524	1118	2007	762	40	838	1041
72	2197	63.5	41	1829	1346	2388	914	48	1016	1219

All reducing fittings NPS 16 and smaller have the same center-to-face dimensions as straight size fittings.

Table 3 Dimensions of Class 25 Gray Iron Flanged Fittings (Cont'd)

GENERAL NOTES:

- (a) Dimensions are in millimeters.
- (b) For facing, see para. 7.2(a).
- (c) For flange bolt holes, refer to Table 8; see also para. 7.6.
- (d) For spot facing, see para. 7.7.
- (e) For intersecting centerlines of side outlets, see para. 7.3.1.
- (f) The flange diameter, bolt circle, and number of bolts are the same in Class 25 as in Class 125. Bolt hole diameters of Class 25 shall not be modified when mated with Class 125 flanges or with steel flanges.
- (g) The center-to-face dimensions of fittings are the same as the Class 125.

NOTES:

- (1) For wall thickness tolerance, see para. 7.1.
- (2) For center-to-face dimensions of reducing elbows and side-outlet elbows, see paras. 7.3.2(b) and (c).
- (3) Tees and crosses, reducing on run only, carry same dimensions center-to-face and face-to-face as a straight-size fitting of the larger opening.
- (4) For reinforcement of crosses, see para. 7.8.
- (5) For center-to-face tolerances, see para. 7.4.
- (6) For center-to-face dimensions of special degree elbows, see para. 7.3.2(d).
- (7) Tees, side-outlet tees, and crosses, NPS 16 and smaller, reducing on the outlet, have the same dimensions center-to-face and face-to-face as straight-size fittings, corresponding to the size of the larger opening. NPS 18 and larger, reducing on the outlet, are made in two lengths, depending on the size of the outlet as given in Table 3.
- (8) Long-body patterns are used when outlets are larger than given above and, therefore, have the same dimensions as straight-size fittings.
- (9) Fittings reducing on the run only carry same dimensions center-to-face and face-to-face as straight-size fittings, corresponding to the size of the larger opening. Tees increasing on outlet, known as bull-head tees, will have same center-to-face and face-to-face dimensions as a straight fitting of the size of the outlet. For example, an NPS 12 × NPS 18 tee will be governed by the dimensions of the NPS 18 long-body tee, given in Table 3, namely NPS 16½ center-to-face of all openings and NPS 33 face-to-face.
- (10) Side-outlet tees, with outlet at 90 deg or any other angle, straight or reducing, carry same dimensions center-to-face and face-to-face as regular tees having same reductions.
- (11) In a side outlet tee, the larger of the two side outlets governs the center-to-face dimension *J*.

Table 4 Dimensions of Class 125 Gray Iron Flanged Fittings

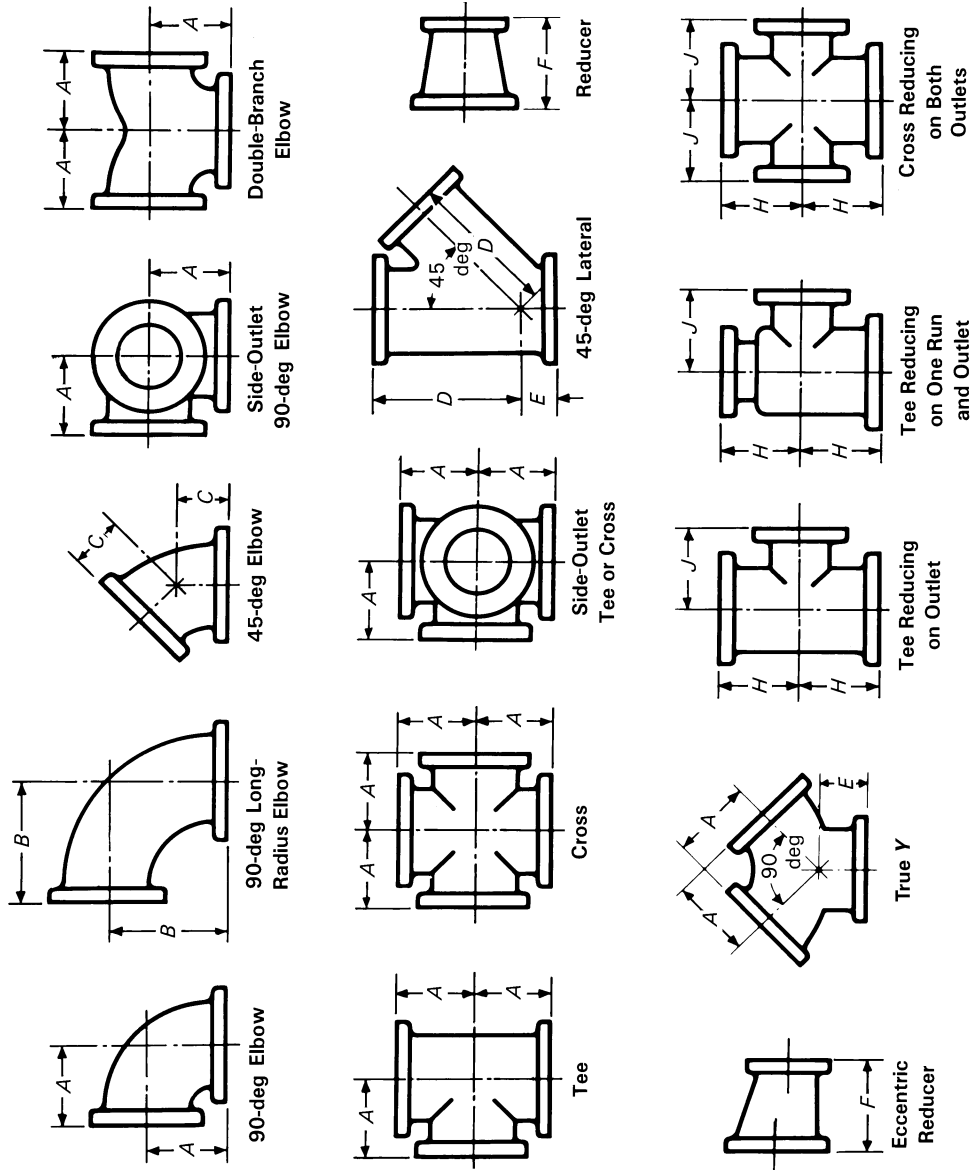

Table 4 Dimensions of Class 125 Gray Iron Flanged Fittings (Cont'd)

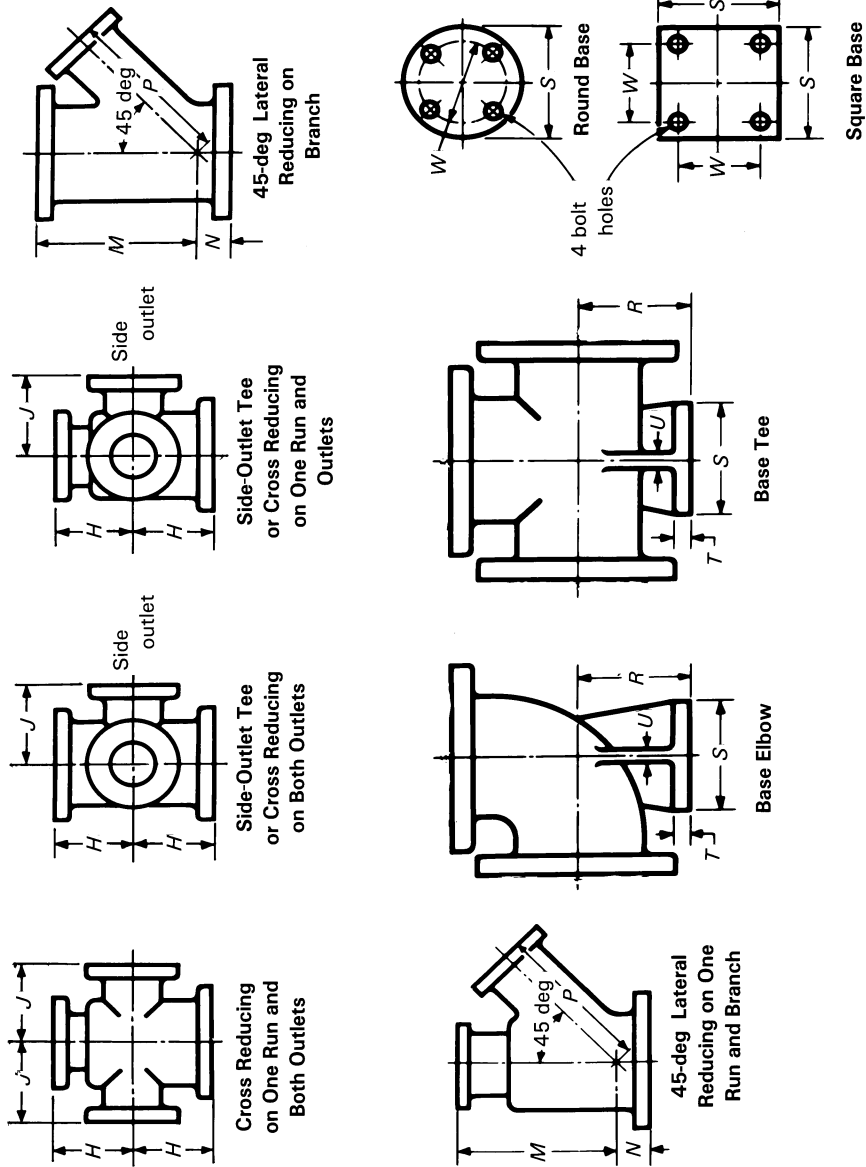

Table 4 Dimensions of Class 125 Gray Iron Flanged Fittings (Cont'd)

NPS	Straight Fittings [Notes (5) and (6)]										Reducing Fittings (Short-Body Patterns) [Notes (11) and (12)]					
	Center-to-Face 90-deg Elbow, Tees, Crosses, True, Y, and Double- Branch Elbow, A					Center- to-Face 90-deg Radius Elbow, B					Short Center- to-Face True, Y and Lateral, E		Tees and Crosses [Notes (9), (13), and (14)]			
	Flange [Notes (1)-(3)]		General			Center- to-Face 45-deg Elbow, C		Center- to-Face Lateral, D		Face- to- Face Reducer, F		NPS Size of Outlet and Smaller [Notes (6) and (10)]			Center- to-Face Outlet or Side Outlet, J	
Diameter of Flange	Minimum Thickness of Flange	Inside Diameter of Fittings	Wall Thickness [Note (4)]	[Notes (6)-(9)]	[Notes (6)-(8)]	[Note (8)]	[Note (9)]	[Note (9)]	[Note (10)]	[Notes (6) and (10)]	H	F	J			
1	108	11.1	25	7.9	89	127	45	146			
1 1/4	118	12.7	32	7.9	95	140	51	159			
1 1/2	127	14.3	38	7.9	102	152	57	178			
2	152	15.9	51	7.9	114	165	64	203	127	140	127	140	140			
2 1/2	178	17.5	64	7.9	127	178	76	241	140	140	140	140	140			
3	191	19.0	76	9.5	140	197	76	254	152	152	152	152	152			
3 1/2	216	23.8	89	11.1	152	216	89	292	165	165	165	165	165			
4	229	23.8	102	12.7	165	229	102	305	178	178	178	178	178			
5	254	23.8	127	12.7	191	260	114	343	203	203	203	203	203			
6	279	25.4	152	14.3	203	292	127	368	229	229	229	229	229			
8	343	28.6	203	15.9	229	356	140	445	279	279	279	279	279			
10	406	30.2	254	19.0	279	419	165	521	305	305	305	305	305			
12	483	31.8	305	20.6	305	483	191	622	356	356	356	356	356			
14	533	34.9	356	22.2	356	546	191	686	406	406	406	406	406			
16	597	36.5	406	25.4	381	610	203	762	457	457	457	457	457			
18	635	39.7	457	27.0	419	673	216	813	483	483	483	483	483			
20	699	42.9	508	28.6	457	737	241	889	508	508	508	508	508			
24	813	47.6	610	31.8	559	864	279	1029	610	610	610	610	610			
30	984	54.0	762	36.5	635	1054	381	1245	762	762	762	762	762			
36	1168	60.3	914	41.3	711	1245	457	...	914	914	914	914	914			
42	1346	66.7	1067	46.0	787	1435	533	...	1067	1067	1067	1067	1067			
48	1511	69.9	1219	50.8	864	1626	610	...	1219	1219	1219	1219	1219			

Table 4 Dimensions of Class 125 Gray Iron Flanged Fittings (Cont'd)

Reducing Fittings (Short-Body Patterns) [Notes (11) and (12)]		Base Elbows and Tees [Notes (15)–(17)]									
NPS Size of Branch and Smaller	Laterals [Note (9)]				Center- to- Base, R	Diameter of Round Base or Width of Square Base, S [Notes (18) and (19)]	Thickness of Base, T	Thickness of Ribs, U	NPS Size of Supporting Pipe for Base	Base Drilling	
	Center- to- Face Run, M	Center- to- Face Run, N	Center- to- Face Branch, P	Bolt Circle or Bolt Spacing, W						Diameter of Holes	
1					89	11	10	3/4	69.9	5/8	
1 1/4					92	11	10	3/4	69.9	5/8	
1 1/2					95	11	13	1	79.4	5/8	
2					105	13	13	1 1/4	88.9	5/8	
2 1/2					114	13	13	1 1/4	88.9	5/8	
3					124	14	13	1 1/2	98.4	5/8	
3 1/2					133	14	13	1 1/2	98.4	5/8	
4					140	16	13	2	120.7	3/4	
5					159	18	16	2 1/2	139.7	3/4	
6					178	18	16	2 1/2	139.7	3/4	
8					213	24	22	4	190.5	3/4	
10					248	24	22	4	190.5	3/4	
12					286	25	25	6	241.3	7/8	
14					318	25	25	6	241.3	7/8	
16					349	25	25	6	241.3	7/8	
18	635	25	699		381	29	29	8	298.5	7/8	
20	686	25	749		406	29	29	8	298.5	7/8	
24	800	13	876		470	29	29	8	298.5	7/8	
30	991	0	1067		

All reducing laterals NPS 16 and smaller shall have the same center-to-face dimensions as straight-size fittings, corresponding to the size of the largest opening.

Table 4 Dimensions of Class 125 Gray Iron Flanged Fittings (Cont'd)

GENERAL NOTE: Dimensions are in millimeters.

NOTES:

- (1) For facing, see para. 7.2(a).
- (2) For flange bolt holes, refer to Table 9 and para. 7.6.
- (3) For spot facing, see para. 7.7.
- (4) For wall thickness tolerances, see para. 7.1.
- (5) For center-to-face tolerances, see para. 7.4.
- (6) For intersecting centerlines of side-outlet fittings, see para. 7.3.1.
- (7) For center-to-face dimensions of reducing elbows and side-outlet elbows, see paras. 7.3.2(b) and (c).
- (8) For center-to-face dimensions of special degree elbows, see para. 7.3.2(d).
- (9) For reinforcement of crosses and laterals, see para. 7.8.
- (10) For face-to-face dimensions of reducers and eccentric reducers, see para. 7.2.5.
- (11) For center-to-face dimensions of tees, and crosses having outlets and laterals having branches larger than given above, see para. 7.3.3(b).
- (12) For center-to-face dimensions of tees, crosses, and laterals reducing on run only, see para. 7.3.3(b).
- (13) For center-to-face dimensions of tees reducing on both runs, known as bull-head tees, see para. 7.3.3(c).
- (14) For center-to-face dimensions of reducing side-outlet tees and crosses having two different size reductions on the outlets, see para. 7.3.3(b).
- (15) Bases are furnished only when specified by the purchaser.
- (16) For tees larger than NPS 24, anchorage fittings are recommended. See Table 6.
- (17) The base dimension applies to all straight and reducing sizes.
- (18) For reducing fittings, the size and center-to-face dimensions of base are determined by the size of the largest opening of the fitting. In the case of reducing base elbows, orders shall specify whether the base shall be opposite the larger or smaller opening.
- (19) Bolt hole template shown for round base is the same as for the flange of the supporting pipe size, except using only four holes in all cases so placed as to straddle centerlines. The bases of these fittings are intended for support in compression and are not to be used for anchors or supports in tension or shear.

Table 5 Dimensions of Class 250 Gray Iron Flanged Fittings

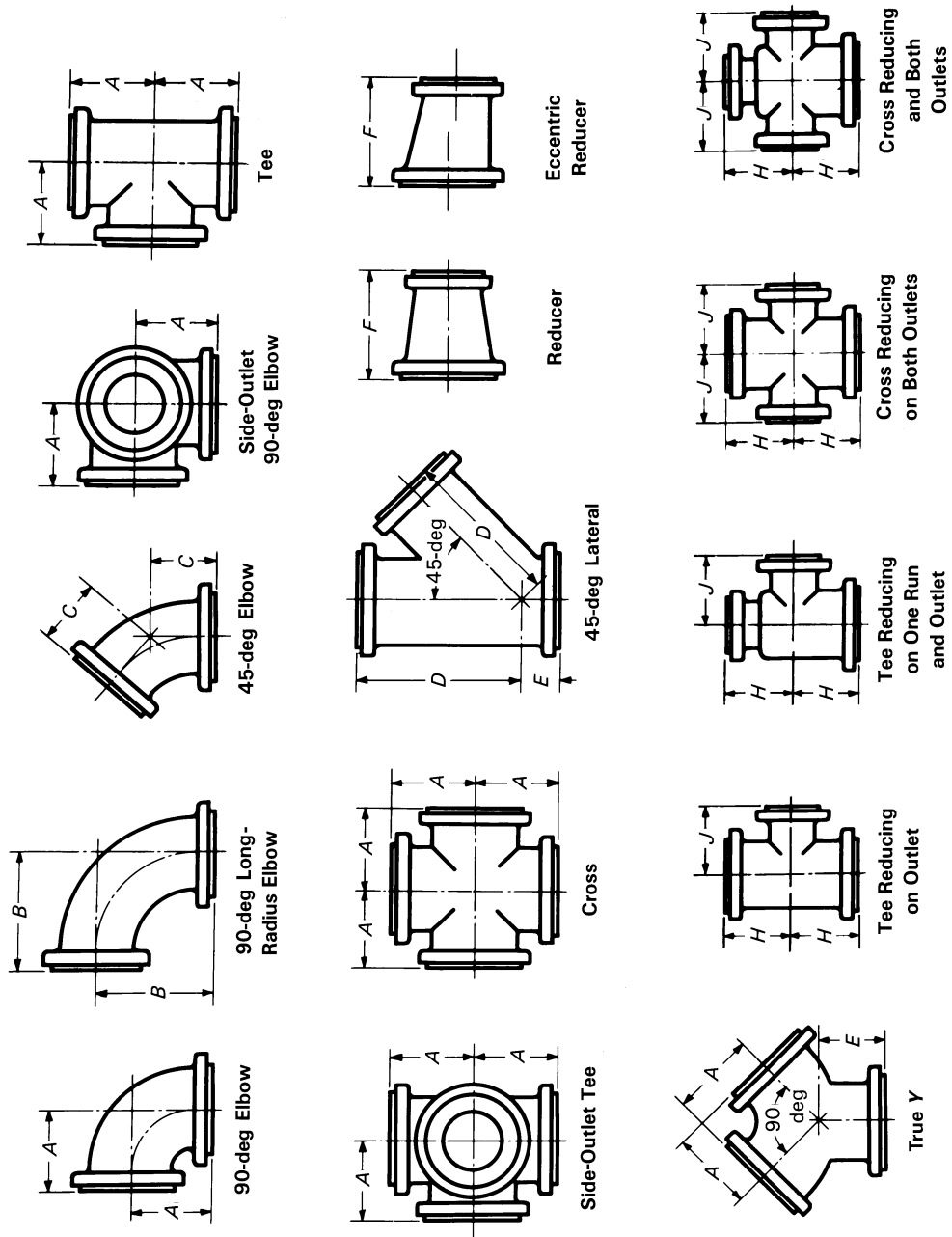

Table 5 Dimensions of Class 250 Gray Iron Flanged Fittings (Cont'd)

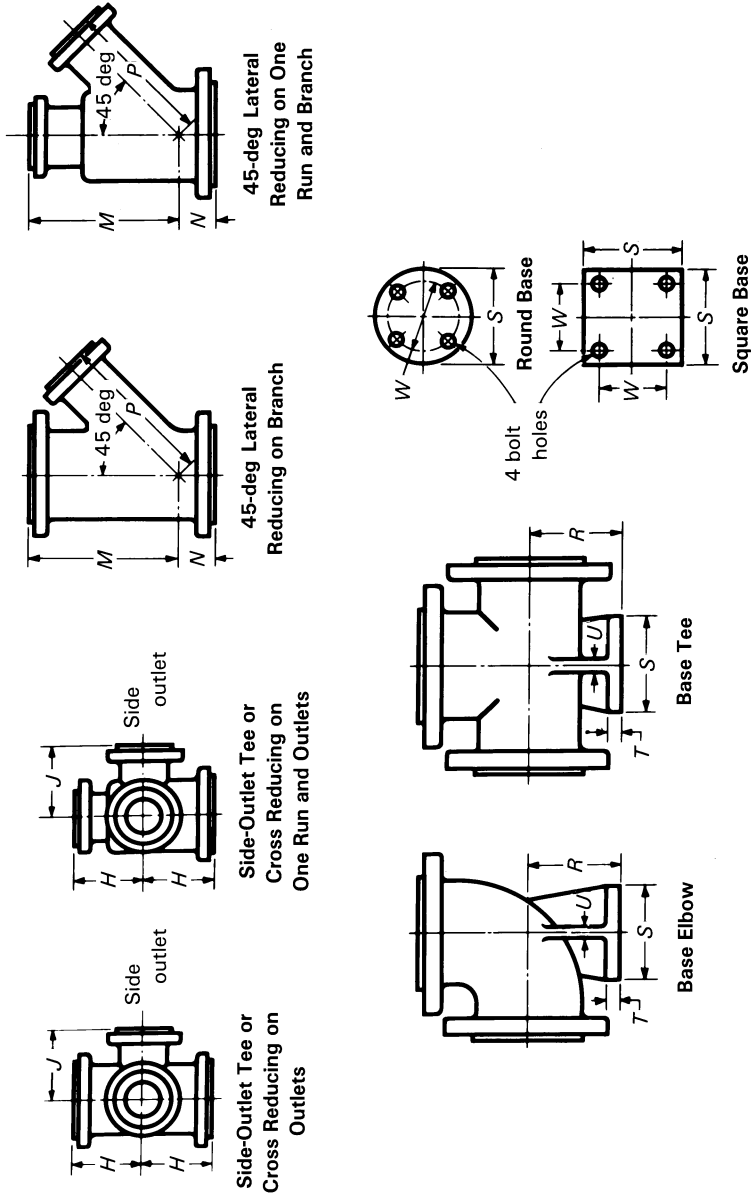

Table 5 Dimensions of Class 250 Gray Iron Flanged Fittings (Cont'd)

NPS	Flanges [Notes (1)–(3)]			General Fittings [Notes (5) and (6)]				Straight Fittings [Notes (5) and (6)]				Reducing (Short Body) [Notes (11) and (15)]						
	Diameter of Flange	Minimum Thickness of Flange, <i>Q</i>	Diameter of Raised Face [Note (4)]	Inside Diameter of		Body Wall Thickness	Fittings [Note (7)]	Center-to-Face 90-deg Elbow, Tees, Crosses, and True, <i>Y</i> , <i>A</i>		Center-to-90-deg Long-Radius Elbow, <i>B</i>	Center-to-Face 45-deg Elbow, <i>C</i>	Center-to-Face Lateral, <i>D</i>		Short Center-to-Face True, <i>Y</i> and Lateral, <i>E</i>	Face-to-Face Reducer, <i>F</i>	NPS Size of Outlet and Smaller [Notes (6) and (12)]	Tees and Crosses [Notes (10), (13), and (14)]	Center-to-Face Outlet or Side Outlet, <i>J</i>
				Diameter	Thickness			[Notes (8)–(10)]	[Note (9)]			[Notes (10) and (11)]	[Notes (10) and (11)]					
1	124	17.5	68	25	11.1	102	127	51	165	57
1¼	133	19.0	78	32	11.1	108	140	64	184	57
1½	156	20.6	91	38	11.1	114	152	70	216	64
2	165	22.2	106	51	11.1	127	165	76	229	64
2½	191	25.4	125	64	12.7	140	178	89	267	64
3	210	28.6	144	76	14.3	152	197	89	279	76
3½	229	30.2	160	89	14.3	165	216	102	318	76
4	254	31.8	176	102	15.9	178	229	114	343	76
5	279	34.9	211	127	17.5	203	260	127	381	89
6	318	36.5	246	152	19.0	216	292	140	445	102
8	381	41.3	303	203	20.6	254	356	152	521	127
10	445	47.6	357	254	23.8	292	419	178	610	140
12	521	50.8	418	305	25.4	330	483	203	699	152
14	584	54.0	481	337	28.6	381	546	216	787	165
16	648	57.2	535	387	31.8	419	609	241	876	191
18	711	60.3	592	432	34.9	457	673	254	953	203
20	775	63.5	649	483	38.1	495	737	267	1029	216
24	916	69.8	770	584	41.3	572	864	305	1207	254
30	1092	76.2	945	737	50.8	699	1054	381

All reducing tees and crosses NPS 16 and smaller shall have the same center-to-face dimensions as straight-size fittings, corresponding to the size of the largest opening.

Table 5 Dimensions of Class 250 Gray Iron Flanged Fittings (Cont'd)

NPS	Reducing (Short Body) [Notes (11) and (15)]				Base, Elbows, and Tees [Notes (16)–(18)]					
	Laterals [Note (10)]				Diameter of Round Base or Width of Square Base, <i>S</i> [Note (19)]	Thickness of Base, <i>T</i>	Thickness of Ribs, <i>U</i>	NPS Size of Supporting Pipe for Base	Base Drilling [Note (20)] Bolt Circle or Bolt Spacing, <i>W</i>	Diameter of Holes
	NPS Size of Branch and Smaller	Center-to-Face Run, <i>M</i>	Center-to-Face Run, <i>N</i>	Center-to-Face Run, <i>P</i>						
2				114	133	19	13	1 1/4	98	3/4
2 1/2				121	133	19	13	1 1/4	98	3/4
3				133	156	21	16	1 1/2	114	7/8
3 1/2				143	156	21	16	1 1/2	114	7/8
4				152	165	22	16	2	127	3/4
5				171	191	25	19	2 1/2	149	7/8
6				191	191	25	19	2 1/2	149	7/8
8				229	254	32	22	4	200	7/8
10				267	254	32	22	4	200	7/8
12				305	318	37	25	6	270	7/8
14				343	318	37	25	6	270	7/8
16				375	318	37	29	6	270	7/8
18	8	787.0	76	413	381	41	29	8	330	1
20	10	864.0	76	454	381	41	32	8	330	1
24	12	1041.0	76	527	445	48	32	10	387	1 1/8

Table 5 Dimensions of Class 250 Gray Iron Flanged Fittings (Cont'd)

GENERAL NOTE: Dimensions are in millimeters.

NOTES:

- (1) For facing, see para. 7.2(b).
- (2) For flange bolt holes, refer to Table 2 and para. 7.6.
- (3) For spot facing, see para. 7.7.
- (4) Tolerance of the diameter of the raised face is equal to ± 0.8 mm.
- (5) For center-to-face tolerances, see para. 7.4.
- (6) For intersecting centerlines of side-outlet fittings, see para. 7.3.1.
- (7) For wall thickness tolerances, see para. 7.1.
- (8) For center-to-face dimensions of reducing elbows and side-outlet elbows, see paras. 7.3.2(b) and (c).
- (9) For center-to-face dimensions of special degree elbows, see para. 7.3.2(d).
- (10) For reinforcement of crosses and laterals, see para. 7.8.
- (11) For center-to-face dimensions of tees and crosses having outlets and laterals having branches larger than given above, see para. 7.3.3(b).
- (12) For face-to-face dimensions of reducers and eccentric reducers, see para. 7.3.5.
- (13) For center-to-face dimensions of tees reducing on both runs, known as bull-head tees, see para. 7.3.3(c).
- (14) For center-to-face dimensions of reducing side-outlet tees and crosses having two different size reductions on the outlet, see para. 7.3.3(b).
- (15) For center-to-face dimensions of tees, crosses, and laterals reducing on run only, see para. 7.3.3(b).
- (16) Bases are furnished only when specified by purchaser.
- (17) The base dimensions apply to all straight and reducing sizes.
- (18) For tees, sizes larger than NPS 24, anchorage fittings are recommended. See Table 7.
- (19) For reducing fittings, the size and center-to-face dimensions of base are determined by the size of the largest opening of the fitting. In the case of reducing base elbows, orders shall specify whether the base shall be opposite the larger or smaller opening.
- (20) Bolt hole template shown for round base is the same as for the flange of the supporting pipe size, except using only four holes in all cases so placed as to straddle centerlines. The bases of these fittings are intended for support in compression and are not to be used for anchors or supports in tension or shear.

Table 6 Dimensions of Anchorage Bases for Straight and Reducing Class 125 Tees

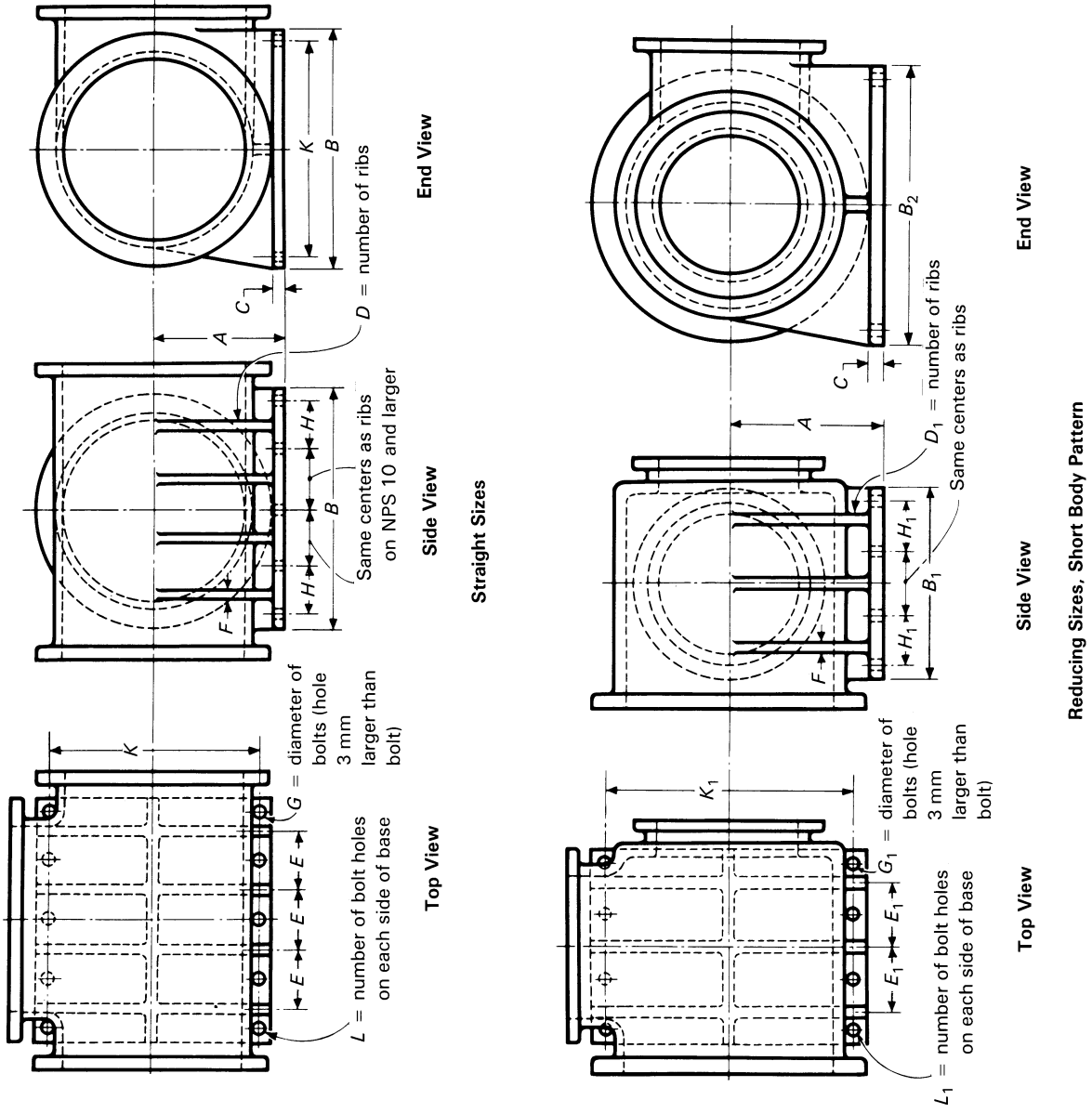

Table 6 Dimensions of Anchorage Bases for Straight and Reducing Class 125 Tees (Cont'd)

NPS	Straight Sizes										Reducing Sizes [Notes (1) and (2)] (Short Body Pattern)											
	Common to Both Straight Sizes and Reducing Sizes					Longitudinal Centers					Longitudinal Centers					Longitudinal Centers						
	Center to Base, A	Thickness of Base, C	Diameter of Bolts, G	Thickness of Ribs, F	Width and Length of Square Base, B	Transverse Bolt Centers, K	Number of Bolt Holes on Each Side of Base, L	Number of Ribs, D	Centers of Ribs and Inside Bolt Holes, E	From End Bolt to Second End, H	NPS Outlet Sizes and Smaller	Length of Base, B ₁ [Note (1)]	Number of Ribs, D ₁	Centers of Ribs, E ₁	Diameter of Bolts, G ₁	From End Bolt to Second Bolt, H ₁	Transverse Bolt Centers, K ₁	Number of Bolt Holes on Each Side of Base, L ₁				
2½	114	18	5/8	11	178	114	2	1	...	114												
3	124	19	5/8	11	191	127	2	1	...	127												
3½	133	21	5/8	11	216	152	2	1	...	152												
4	140	24	5/8	13	229	165	3	2	108	83												
5	159	24	7/8	13	254	191	3	2	127	95												
6	178	25	7/8	14	279	222	3	2	152	111												
8	273	29	1	16	343	279	3	2	203	140												
10	248	30	1 1/8	19	406	340	4	3	124	108												
12	286	32	1 1/4	21	483	394	4	3	146	124												
14	318	35	1 1/4	22	533	451	4	3	172	140												
16	349	37	1 3/8	25	597	502	4	3	197	152												
18	381	40	1 7/8	27	635	552	4	3	216	168				12	483	3	133	1 1/4	130	546	4	629
20	406	43	1 1/2	29	699	610	4	3	241	184				14	533	3	152	1 1/4	137	591	4	679
24	470	48	1 7/8	32	813	721	4	3	289	216				16	597	3	178	1 3/8	159	711	4	803
30	559	54	1 3/4	37	984	876	5	4	238	200				20	699	3	229	1 1/2	184	883	4	991
36	648	60	1 7/8	41	1168	1035	5	4	286	232				24	813	3	273	1 1/2	213	1054	4	1187
42	743	67	2	46	1346	1187	5	4	330	264				24	927	4	216	1 5/8	191	1232	5	1391
48	832	70	2 1/4	51	1511	1353	5	4	378	298				30	1060	4	248	1 7/8	210	1365	5	1524

Reducing tee sizes NPS 16 and smaller shall have the same base (B) dimensions as a straight-size tee, corresponding to the size of the largest opening.

GENERAL NOTES:

- (a) Dimensions are in millimeters.
- (b) Bases are furnished only when specified by the purchaser.
- (c) For tee dimensions, refer to Table 4.

NOTES:

- (1) For NPS 18 and larger, if the outlet is the same size or smaller than given for reducing tees, the base dimensions shown in this table shall be used. If the outlet is larger than shown for reducing tees, the base dimensions shall be the same as for the straight-size tee, corresponding to the size of the largest opening.
- (2) Tees reducing on run only shall have the same base dimensions as straight-size tees, corresponding to the size of the largest opening.

Table 7 Dimensions of Anchorage Bases for Straight and Reducing Class 250 Tees

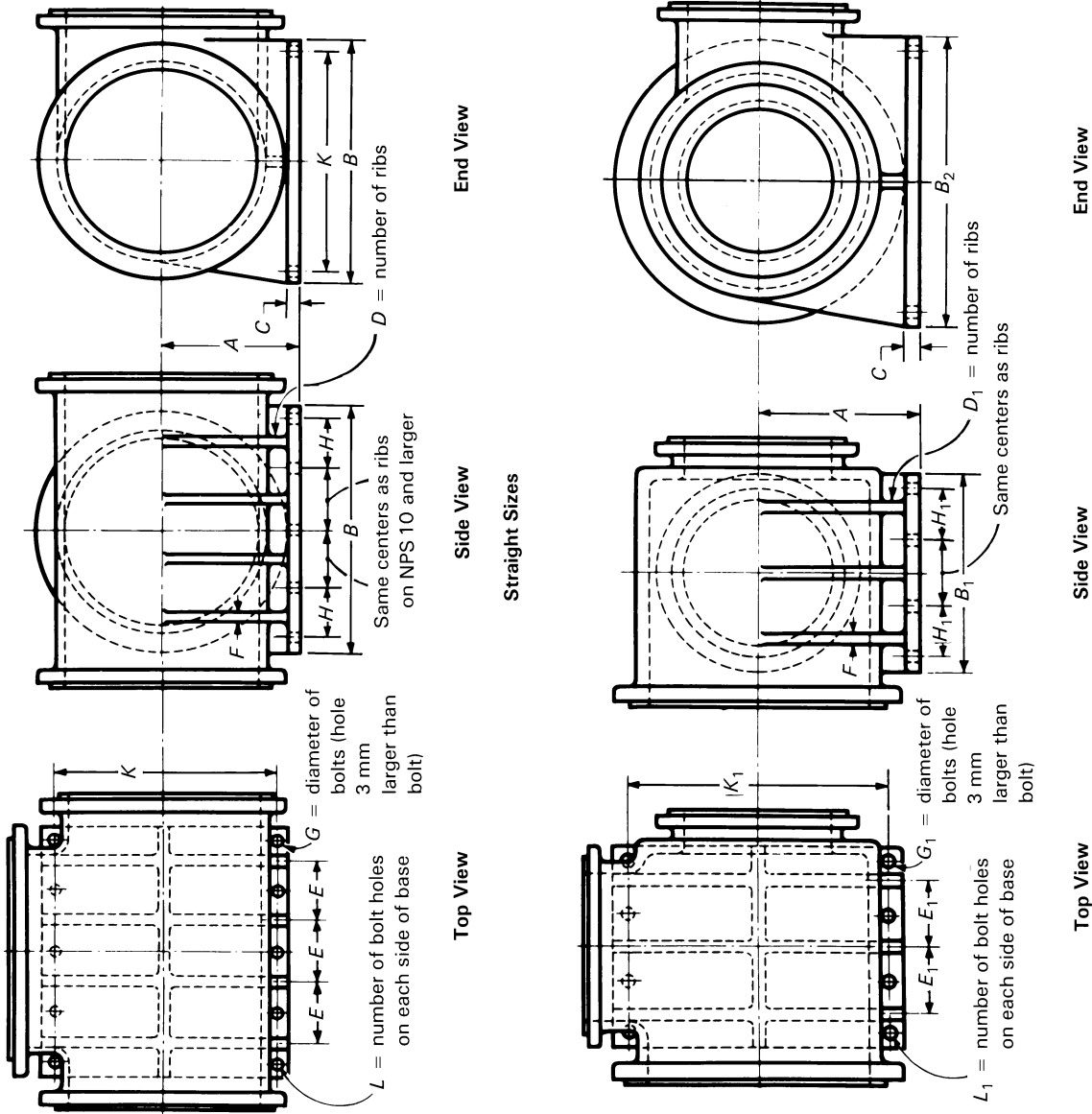

Table 7 Dimensions of Anchorage Bases for Straight and Reducing Class 250 Tees (Cont'd)

NPS	Common on Both Straight Sizes and Reducing Sizes										Straight Sizes						Reducing Sizes (Short-Body Pattern) [Notes (2) and (3)]					
	Center to Base, [Notes (1) and (2)]		Diameter of Bolts, G	Thickness of Bolts, F	Length of Square Base, B	Transverse Bolt Centers, K	Number of Holes on Each Side of Base, L	Number of Ribs, D	Centers of Ribs, and Inside Bolt Holes, E	Longitudinal Centers From Bolt to Second End, H	NPS Outlet Sizes and Smaller [Note (2)]	Length of Base, B ₁	Centers of Ribs, E ₁	Longitudinal Centers From Bolt to Second End, H ₁	Transverse Bolt Centers, K ₁	Width of Base, B ₂						
	A	C																				
2½	121	19	5/8	14	190	146	2	1	...	146						
3	133	21	5/8	14	210	165	2	1	...	165						
3½	143	24	5/8	14	229	184	2	1	...	184						
4	152	24	7/8	16	254	197	3	2	102	98						
5	171	25	7/8	18	279	222	3	2	127	111						
6	190	27	7/8	19	318	260	3	2	152	130						
8	229	29	1	21	381	318	3	2	203	159						
10	267	32	1½	24	444	375	4	3	127	124						
12	305	32	1¼	25	521	444	4	3	152	146						
14	343	35	1¼	29	584	508	4	3	178	165						
16	375	40	1¾	32	648	559	4	3	203	178						
18	413	43	1¾	35	711	616	4	3	229	194						
20	454	48	1½	38	775	679	4	3	254	213						
24	527	52	1½	41	914	806	4	3	305	251						
30	629	59	1¾	51	1092	965	5	4	254	229						

Reducing tee sizes NPS 16 and smaller shall have the same base (B) dimensions as a straight-size tee, corresponding to the size of the largest opening.

GENERAL NOTES:

- (a) Dimensions are in millimeters.
- (b) For tee dimensions, refer to Table 5.

NOTES:

- (1) Bases are furnished only when specified by the purchaser.
- (2) For NPS 18 and larger, if the outlet is the same size or smaller than given for reducing tees, the base dimensions shown in this table for reducing tees shall be used. If the outlet is larger than shown for reducing tees, the base dimensions shall be the same as for the straight-size tees, corresponding to the size of the largest opening.
- (3) Tees reducing on run only shall have the same base dimensions as straight-size tees, corresponding to the size of the largest opening.

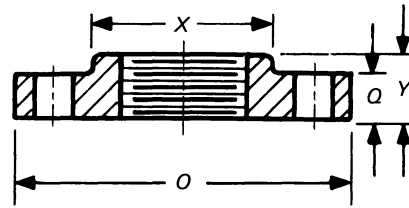
Table 8 Class 25 Flange and Bolting Dimensions

NPS	Flanges		Hub		Bolt Holes		Bolting [Note (6)]		
	Diameter, O	Minimum Thickness, Q [Notes (1) and (2)]	Minimum Diameter, X	Minimum Length, Y	Diameter of Bolt Circle [Note (3)]	Diameter of Bolt Holes [Notes (3)–(5)]	Number of Bolts	Diameter of Bolts [Note (3)]	Length of Bolts
4	230	19.0	135	33	191	$\frac{3}{4}$	8	$\frac{5}{8}$	64
5	255	19.0	164	37	216	$\frac{3}{4}$	8	$\frac{5}{8}$	64
6	280	19.0	192	40	241	$\frac{3}{4}$	8	$\frac{5}{8}$	64
8	345	19.0	246	45	299	$\frac{3}{4}$	8	$\frac{5}{8}$	64
10	405	22.2	303	49	368	$\frac{3}{4}$	12	$\frac{5}{8}$	70
12	485	25.4	357	56	432	$\frac{3}{4}$	12	$\frac{5}{8}$	76
14	535	28.6	391	57	476	$\frac{7}{8}$	12	$\frac{3}{4}$	89
16	595	28.6	445	64	540	$\frac{7}{8}$	16	$\frac{3}{4}$	89
18	635	31.8	498	68	578	$\frac{7}{8}$	16	$\frac{3}{4}$	95
20	700	31.8	552	78	635	$\frac{7}{8}$	20	$\frac{3}{4}$	95
24	815	34.9	560	83	749	$\frac{7}{8}$	20	$\frac{3}{4}$	102
30	985	38.1	914	1	28	$\frac{7}{8}$	114
36	1170	41.3	1085	1	32	$\frac{7}{8}$	121
42	1345	44.5	1257	$1\frac{1}{8}$	36	1	133
48	1510	50.8	1422	$1\frac{1}{8}$	44	1	146
54	1685	57.2	1594	$1\frac{1}{8}$	44	1	159
60	1855	57.2	1759	$1\frac{1}{4}$	52	$1\frac{1}{8}$	159
72	2195	63.5	2095	$1\frac{1}{4}$	60	$1\frac{1}{8}$	172
84	2535	69.9	2425	$1\frac{3}{8}$	64	$1\frac{1}{4}$	191
96	2875	76.2	2756	$1\frac{3}{8}$	68	$1\frac{1}{4}$	203

GENERAL NOTE: Dimensions are in millimeters.

NOTES:

- (1) For facing, see para. 7.2(a).
- (2) Threaded companion flanges should not be thinner than the Class 125 thickness on NPS 24 and smaller. Other types of flanges may have thicknesses as given above.
- (3) The flange diameter, bolt circle, and number of bolts are the same in Class 25 as in Class 125. Bolt hole diameters of Class 25 shall not be modified when mated with Class 125 flanges or with steel flanges.
- (4) For spot facing, see para 7.7.
- (5) For flange bolt holes, see para. 7.6.
- (6) For bolts and nuts, see para. 8.1.

Table 9 Class 125 Flange and Bolting Dimensions

(15)

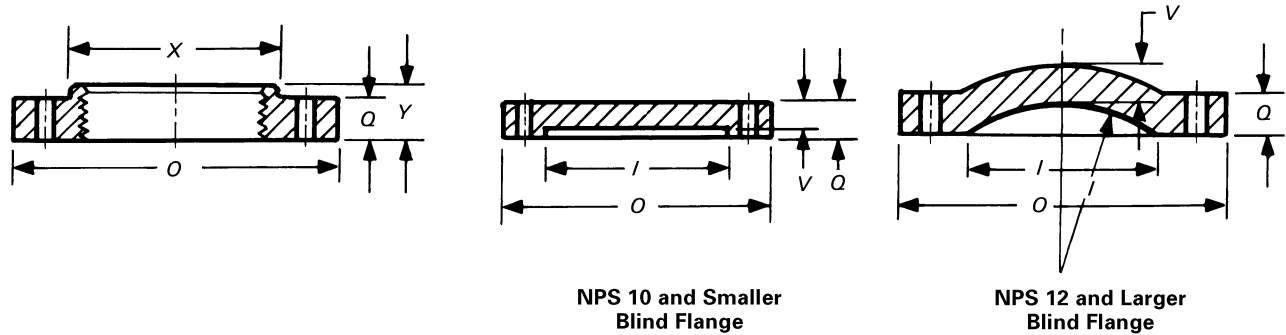

NPS	Flanges		Hub		Blind Flanges		Bolt Holes		Bolting			Length of Bolt Stud With Two Nuts [Note (7)]
	Diameter of Flange, O	Minimum Thickness of Flange, Q [Note (1)]	Minimum Diameter, X	Minimum Length of Hub and Threads, Y [Note (2)]	Diameter of Port, I [Note (3)]	Wall Thickness, V [Note (4)]	Diameter of Bolt Circle	Diameter of Bolt Holes [Notes (5) and (6)]	Number of Bolts	Diam-eter of Bolts [Notes (7) and (8)]	Length of Bolts [Notes (7) and (8)]	
1	110	11.1	49	18	25	9.6	79	5/8	4	1/2	45	...
1 1/4	115	12.7	59	21	32	11.1	89	5/8	4	1/2	51	...
1 1/2	125	14.3	65	22	38	12.7	98	5/8	4	1/2	51	...
2	150	15.9	78	25	51	14.3	121	3/4	4	5/8	57	...
2 1/2	180	17.5	91	29	64	15.9	140	3/4	4	5/8	64	...
3	190	19.0	108	30	76	17.5	152	3/4	4	5/8	64	...
3 1/2	215	20.6	122	32	89	19.0	178	3/4	8	5/8	70	...
4	230	23.8	135	33	102	22.2	191	3/4	8	5/8	76	...
5	255	23.8	164	37	127	22.2	216	7/8	8	3/4	76	...
6	280	25.4	192	40	152	23.8	241	7/8	8	3/4	83	...
8	345	28.6	246	45	203	27.0	299	7/8	8	3/4	89	...
10	405	30.2	303	49	254	28.6	362	1	12	7/8	95	...
12	485	31.8	357	56	305	20.6	432	1	12	7/8	95	...
14	535	35.1	391	57	356	22.2	476	1 1/8	12	1	108	...
16	595	36.5	445	64	406	25.4	540	1 1/8	16	1	114	...
18	635	39.7	499	68	457	27.0	578	1 1/4	16	1 1/8	121	...
20	700	42.9	553	73	508	28.6	635	1 1/4	20	1 1/8	127	...
24	815	47.6	660	83	610	31.8	749	1 3/8	20	1 1/4	140	...
30	985	54.0	762	36.6	914	1 3/8	28	1 1/4	159	...
36	1170	60.3	914	41.3	1086	1 5/8	32	1 1/2	178	222
42	1345	66.7	1066	46.0	1257	1 5/8	36	1 1/2	191	235
48	1510	69.9	1219	50.8	1422	1 5/8	44	1 1/2	197	242
54 (9)	1685	76.2	1594	2	44	1 3/4	216	267
60 (9)	1855	79.4	1759	2	52	1 3/4	222	273
72 (9)	2195	88.9	2096	2	60	1 3/4	241	292
84 (9)	2535	98.4	2426	2 1/4	64	2	267	324
96 (9)	2875	108.0	2756	2 1/2	68	2 1/4	292	356

GENERAL NOTE: Dimensions are in millimeters.

NOTES:

- (1) For facing, see para. 7.2.(a)
- (2) For thread of threaded flanges, see paras. 7.5.1 and 7.5.2.
- (3) All blind flange NPS 12 and larger must be dished with inside radius equal to the port diameter.
- (4) For wall thickness tolerance, see para. 7.1.
- (5) For flange bolt holes, see para. 7.6.
- (6) For spot facing, see para. 7.7.
- (7) For bolts and nuts, see para. 8.1.1.
- (8) Bolt lengths to be compensated for when bolting steel to gray iron flanges.
- (9) NPS 54 through 96 are included for convenience. Pressure-temperature ratings are the user's responsibility.

Table 10 Minimum Thread Length

Tap Size, NPS	Thread Length, A, mm
$\frac{3}{8}$	10.4
$\frac{1}{2}$	13.5
$\frac{3}{4}$	14.0
1	17.3
$1\frac{1}{4}$	18.0
$1\frac{1}{2}$	18.3
2	19.3

MANDATORY APPENDIX I DIMENSIONS OF FITTINGS IN U.S. CUSTOMARY UNITS

This Appendix provides tables of the standard inch dimensions for fittings.

Fig. I-1 Method of Designating Outlets of Reducing Fittings in Specifications

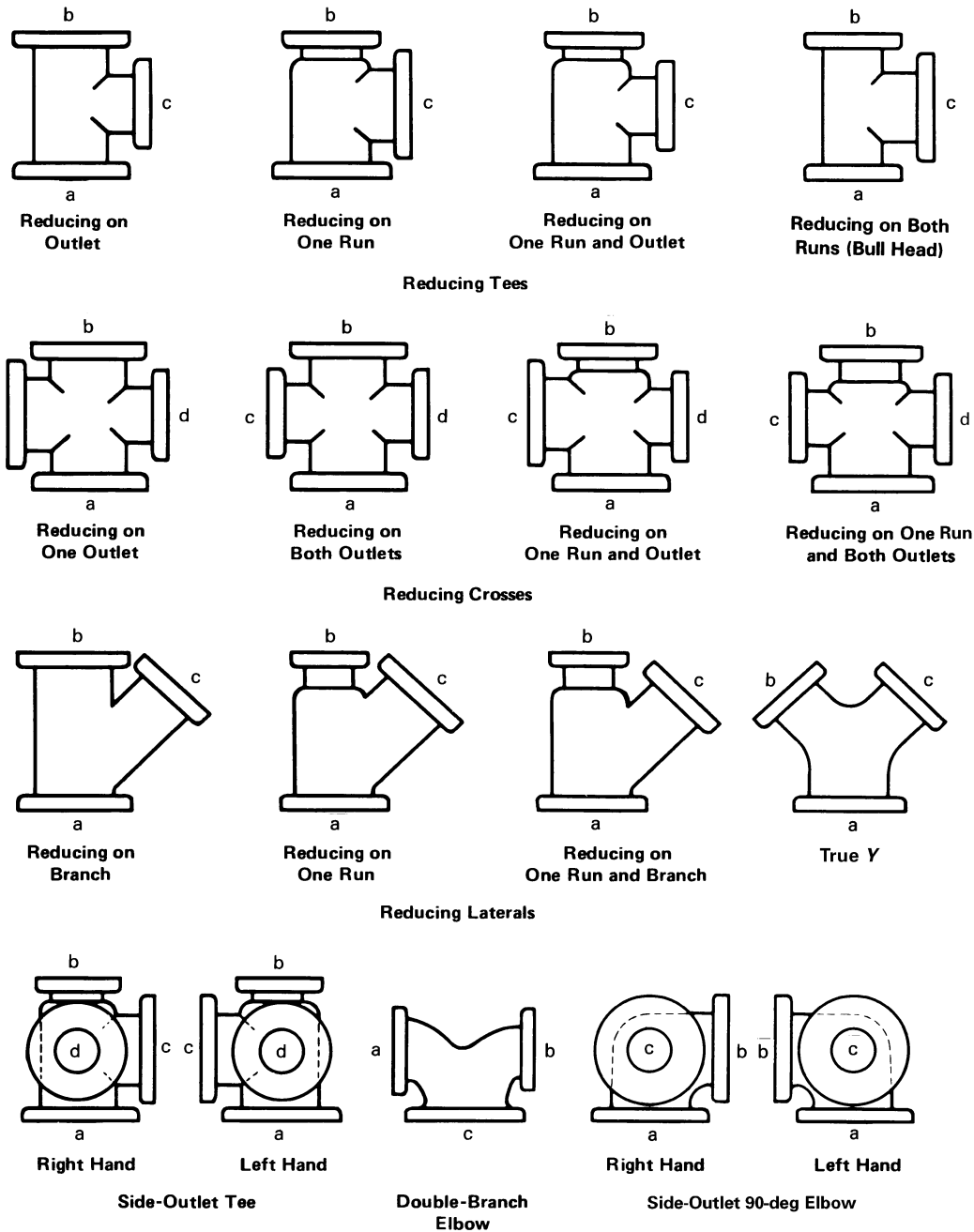

GENERAL NOTES:

- (a) The largest opening establishes the basic size of reducing fitting. The largest opening is named first, except for bull-head tees, which are reducing on both runs, and double-branch elbows where both branches are reducing; the outlet is the largest opening and named last in both cases.
- (b) In designating the openings of reducing fittings, they should be read in the order indicated by the sequence of the letters a, b, c, and d. In designating the outlets of side-outlet reducing fittings, the side outlet is named last; and in the case of the cross (which is not shown), the side outlet is designated by the letter e.

Fig. I-2 Drain Connections

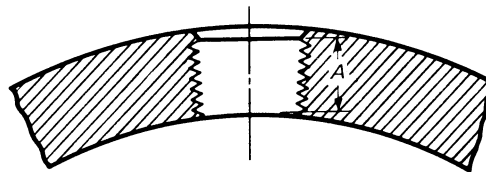
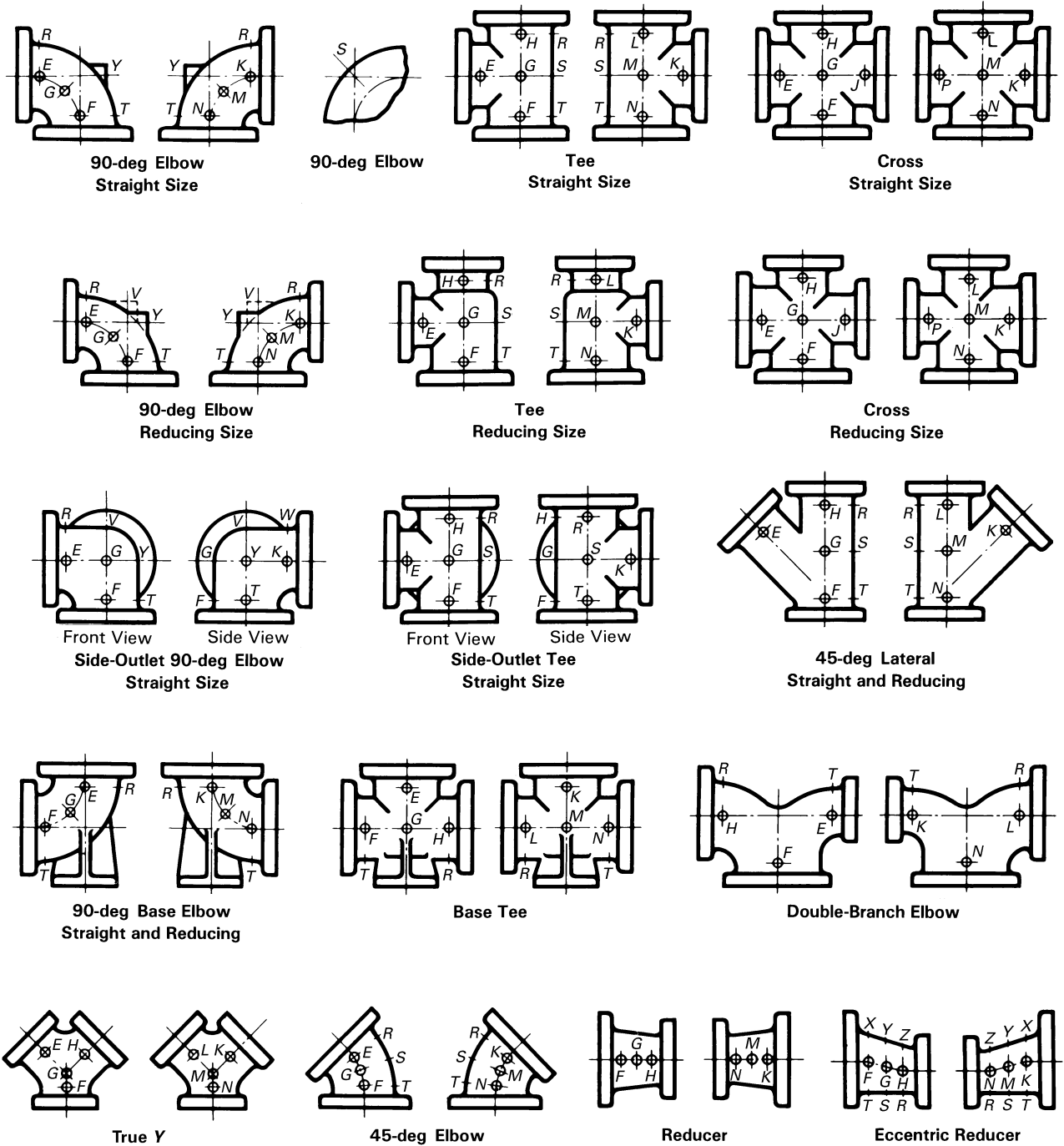

Fig. I-3 Method of Designating Location of Tapped Holes for Drains When Specified



GENERAL NOTE: The above sketches show two views of the same fitting and represent fittings with symmetrical shapes, with the exception of the side-outlet elbow and the side-outlet tee (straight sizes).

Table I-1 Pressure–Temperature Ratings

Temperature, °F	Class 25 [Note (1)] ASTM A126 Class A		Class 125 ASTM A126				Class 250 [Note (1)] ASTM A126			
			Class A	Class B			Class A	Class B		
	NPS 4–36	NPS 42–96	NPS 1–12	NPS 1–12	NPS 14–24	NPS 30–48	NPS 1–12	NPS 1–12	NPS 14–24	NPS 30–48
–20 to 150	45	25	175	200	150	150	400	500	300	300
200	40	25	165	190	135	115	370	460	280	250
225	35	25	155	180	130	100	355	440	270	225
250	30	25	150	175	125	85	340	415	260	200
275	25	25	145	170	120	65	325	395	250	175
300	140	165	110	50	310	375	240	150
325	130	155	105	...	295	355	230	125
353 (2)	125	150	100	...	280	335	220	100
375	145	265	315	210	...
406 (3)	140	250	290	200	...
425	130	270
450	125	250
Hydrostatic Shell Test Pressures [Note (4)]										
100	70	40	270	300	230	230	600	750	450	450

GENERAL NOTE: Pressure is in psi.

NOTES:

(1) Limitations:

(a) Class 25. When Class 25 gray iron flanges and flanged fittings are used for gaseous service, the maximum pressure shall be limited to 25 psi. Tabulated pressure–temperature ratings above 25 psi. for Class 25 gray iron flanges and flanged fittings are applicable for nonshock hydraulic service only.

(b) Class 250. When used for liquid service, the tabulated pressure–temperature ratings NPS ≥ 14 are applicable to Class 250 flanges only and not to Class 250 fittings.

(2) 353°F to reflect the temperature of saturated steam at 125 psi.

(3) 406°F to reflect the temperature of saturated steam at 250 psi.

(4) Hydrostatic tests are not required unless specified by the user.

Table I-2 Class 250 Flange and Bolting Dimensions

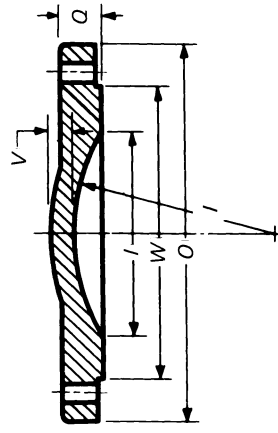

**NPS 10 and Larger
Blind Flange**

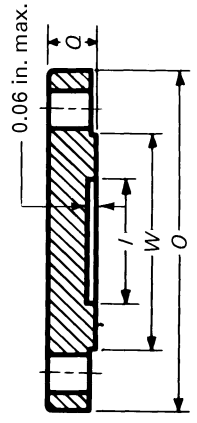

**NPS 8 and Smaller
Blind Flange**

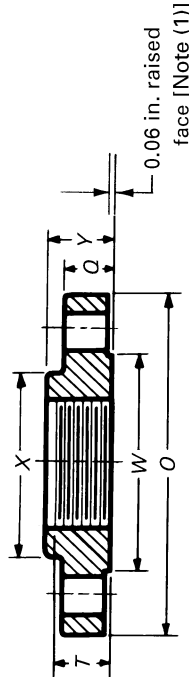

NPS	Flanges		Blind Flanges [Note (2)]		Hubs		Bolt Holes		Bolting [Note (6)]		Length of Stud Bolts [Note (8)]		
	Diameter of Flange, O	Minimum Thickness of Flange, Q	Diameter of Raised Face, W	Diameter of Port, I	Wall Thickness, V	Minimum Diameter of Hub, X	Minimum Length Through Hub, Y	Diameter of Bolt Circle	Diameter of Bolt Holes	Number of Bolts		Diameter of Bolts [Note (7)]	Length of Bolts [Note (8)]
1	4.88	0.69	2.69	1.00	...	2.06	0.88	3.50	3/4	4	0.62	2.50	
1 1/4	5.25	0.75	3.06	1.25	...	2.50	1.00	3.88	3/4	4	0.62	2.50	
1 1/2	6.12	0.81	3.56	1.50	...	2.75	1.12	4.50	7/8	4	0.75	3.00	
2	6.50	0.88	4.19	2.00	...	3.31	1.25	5.00	3/4	8	0.62	3.00	
2 1/2	7.50	1.00	4.94	2.50	...	3.94	1.43	5.88	7/8	8	0.75	3.50	
3	8.25	1.12	5.69	3.00	...	4.62	1.56	6.62	7/8	8	0.75	3.50	
3 1/2	9.00	1.19	6.31	3.50	...	5.25	1.62	7.25	7/8	8	0.75	3.50	
4	10.00	1.25	6.94	4.00	...	5.75	1.75	7.88	7/8	8	0.75	4.00	
5	11.00	1.38	8.31	5.00	...	7.00	1.88	9.25	7/8	8	0.75	4.00	
6	12.50	1.44	9.69	6.00	...	8.12	1.94	10.62	7/8	12	0.75	4.00	
8	15.00	1.62	11.94	8.00	...	10.25	2.19	13.00	1	12	0.88	4.50	
10	17.50	1.88	14.06	10.00	0.94	12.62	2.38	15.25	1 1/8	16	1.00	5.50	
12	20.50	2.00	16.44	12.00	1.00	14.75	2.56	17.75	1 1/4	16	1.12	5.50	
14	23.00	2.12	18.94	13.25	1.12	16.25	2.69	20.25	1 1/4	20	1.12	6.00	
16	25.50	2.25	21.06	15.25	1.25	18.38	2.88	22.50	1 3/8	20	1.25	6.50	

Table I-2 Class 250 Flange and Bolting Dimensions (Cont'd)

NPS	Flanges		Blind Flanges [Note (3)]			Hubs			Bolt Holes			Bolting [Note (7)]		
	Diameter of Flange, <i>O</i>	Minimum Thickness of Flange, <i>Q</i>	Diameter of Raised Face, <i>W</i> [Note (2)]	Diameter of Port, <i>I</i>	Wall Thickness, <i>V</i> [Note (4)]	Minimum Diameter of Hub, <i>X</i>	Minimum Length Through Hub, <i>Y</i>	Minimum Length of Threads, <i>T</i> [Note (5)]	Diameter of Bolt Circle	Diameter of Bolt Holes	Number of Bolts	Diameter of Bolts [Note (8)]	Length of Bolts [Note (9)]	Length of Stud Bolts [Note (9)]
18	28.00	2.38	23.31	17.00	1.38	24.75	1 ³ / ₈	24	1.25	6.50	...
20	30.50	2.50	25.56	19.00	1.50	27.00	1 ³ / ₈	24	1.25	7.00	...
24	36.00	2.75	30.31	23.00	1.62	32.00	1 ⁵ / ₈	24	1.50	7.50	9.50
30	43.00	3.00	37.19	29.00	2.00	39.25	2	28	1.75	8.50	10.50
36 (10)	50.00	3.38	43.69	46.00	2 ¹ / ₄	32	2.00	9.50	12.00
42 (10)	57.00	3.69	50.44	52.75	2 ¹ / ₄	36	2.00	10.00	12.50
48 (10)	65.00	4.00	58.44	60.75	2 ¹ / ₄	40	2.00	11.00	13.00

GENERAL NOTE: Dimensions are in inches.

NOTES:

- (1) Diameter of raised face has tolerance of ±0.8 mm.
- (2) For facings, see para. 7.2(b).
- (3) All blind flanges for NPS 10 and larger must be dished with inside radius equal to the port diameter.
- (4) For wall thickness tolerance, see para. 7.1.
- (5) For thread of threaded flanges, see paras. 7.5.1 and 7.5.3.
- (6) For flange bolt holes, see para. 7.6.
- (7) For bolts and nuts, see para. 8.1.
- (8) For spot facing, see para. 7.7.
- (9) When bolting to steel flanges, longer bolts or studs shall be used.
- (10) Fittings in these sizes are not produced and used in sufficient quantities to warrant standardization; however, the flange dimensions are included for convenience where special fittings larger than NPS 30 are required. When these fittings are made, the body structure should be designed to be the equivalent of the flanges in service pressure ratings.

Table I-3 Dimensions of Class 25 Gray Iron Flanged Fittings

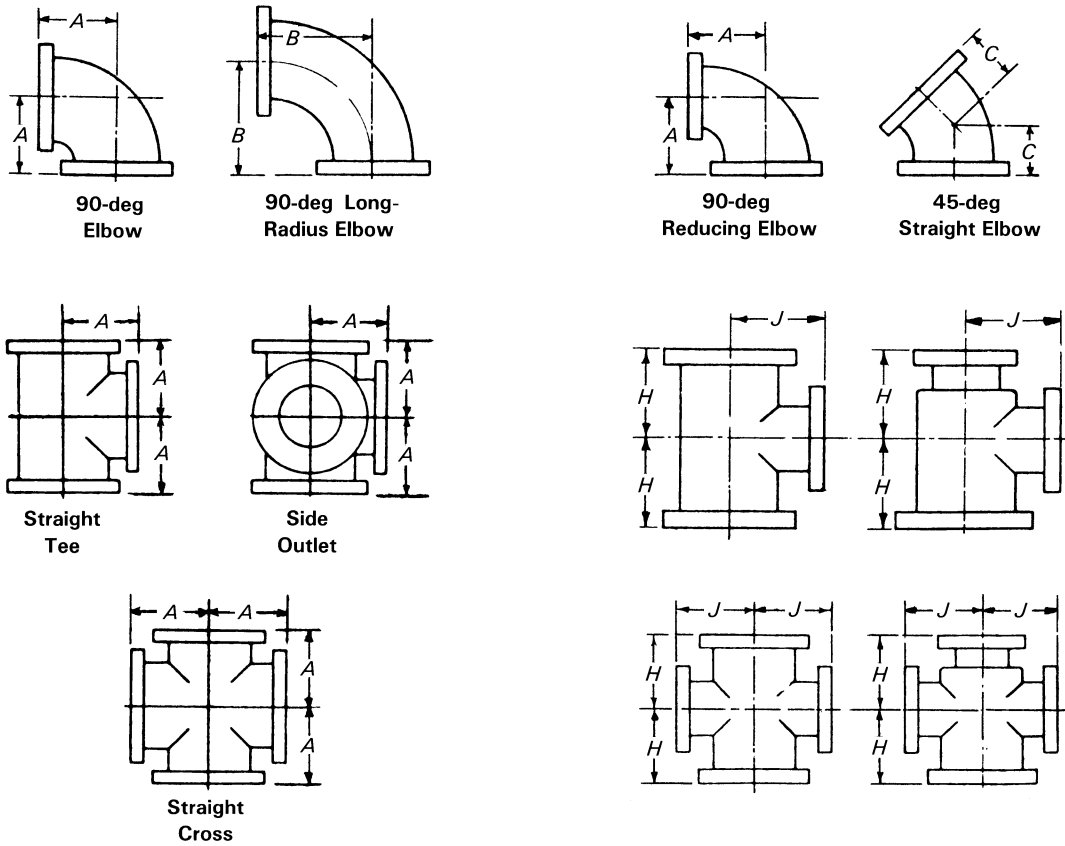

Straight Fittings

Reducing Fittings

NPS	General				Straight Size [Note (5)]			Reducing Tees and Crosses (Short-Body Pattern) [Notes (9)–(11)]		
	Diameter of Flange	Minimum Thickness of Flange	Wall Thickness of Body [Note (1)]	Inside Diameter of Fitting	Center-to-Face Elbow, Tee, and Cross, A [Notes (2)–(4)]	Center-to-Face Long-Radius Elbow, B	Center-to-Face 45-deg Elbow, C [Note (6)]	NPS Size of Outlet and Smaller [Notes (7) and (8)]	Center-to-Face Run, H [Note (5)]	Center-to-Face Outlet, J [Note (5)]
4	9.00	0.75	0.42	4	6.5	9.00	4.0			
5	10.00	0.75	0.44	5	7.5	10.25	4.5			
6	11.00	0.75	0.44	6	8.0	11.50	5.0			
8	13.50	0.75	0.46	8	9.0	14.00	5.5			
10	16.00	0.88	0.50	10	11.0	16.50	6.5			
12	19.00	1.00	0.54	12	12.0	19.00	7.5			
14	21.00	1.12	0.57	14	14.0	21.50	7.5			
16	23.50	1.12	0.60	16	15.0	24.00	8.0			
18	25.00	1.25	0.64	18	16.5	26.50	8.5	12.0	13.0	15.5
20	27.50	1.25	0.67	20	18.0	29.00	9.5	14.0	14.0	17.0
24	32.00	1.38	0.76	24	22.0	34.00	11.0	16.0	15.0	19.0
30	38.75	1.50	0.88	30	25.0	41.50	15.0	20.0	18.0	23.0
36	46.00	1.62	0.99	36	28.0	49.00	18.0	24.0	20.0	26.0
42	53.00	1.75	1.10	42	31.0	56.50	21.0	24.0	23.0	30.0
48	59.50	2.00	1.26	48	34.0	64.00	24.0	30.0	26.0	34.0
54	66.25	2.25	1.35	54	39.0	71.50	27.0	36.0	29.0	37.0
60	73.00	2.25	1.39	60	44.0	79.00	30.0	40.0	33.0	41.0
72	86.50	2.50	1.62	72	53.0	94.00	36.0	48.0	40.0	48.0

All reducing fittings NPS 16 and smaller have the same center-to-face dimensions as straight-size fittings.

Table I-3 Dimensions of Class 25 Gray Iron Flanged Fittings (Cont'd)

GENERAL NOTES:

- (a) Dimensions are in inches.
- (b) For facing, see para. 7.2(a).
- (c) For flange bolt holes, refer to Table I-8; see also para. 7.6.
- (d) For spot facing, see para. 7.7.
- (e) For intersecting centerlines of side outlets, see para. 7.3.1.
- (f) The flange diameter, bolt circle, and number of bolts are the same in Class 25 as in Class 125. Bolt hole diameters of Class 25 shall not be modified when mated with Class 125 flanges or with steel flanges.
- (g) The center-to-face dimensions of fittings are the same as the Class 125.

NOTES:

- (1) For wall thickness tolerance, see para. 7.1.
- (2) For center-to-face dimensions of reducing elbows and side-outlet elbows, see paras. 7.3.2(b) and (c).
- (3) Tees and crosses, reducing on run only, carry same dimensions center-to-face and face-to-face as a straight-size fitting of the larger opening.
- (4) For reinforcement of crosses, see para. 7.8.
- (5) For center-to-face tolerances, see para. 7.4.
- (6) For center-to-face dimensions of special degree elbows, see para. 7.3.2(d).
- (7) Tees, side-outlet tees, and crosses, NPS 16 and smaller, reducing on the outlet, have the same dimensions center-to-face and face-to-face as straight-size fittings, corresponding to the size of the larger opening. NPS 18 and larger, reducing on the outlet, are made in two lengths, depending on the size of the outlet as given in Table I-3.
- (8) Long-body patterns are used when outlets are larger than given above and, therefore, have the same dimensions as straight-size fittings.
- (9) Fittings reducing on the run only carry same dimensions center-to-face and face-to-face as straight-size fittings, corresponding to the size of the larger opening. Tees increasing on outlet, known as bull-head tees, will have same center-to-face and face-to-face dimensions as a straight fitting of the size of the outlet. For example, an NPS 12 × NPS 18 tee will be governed by the dimensions of the NPS 18 long-body tee, given in Table I-3, namely NPS 16½ center-to-face of all openings and NPS 33 face-to-face.
- (10) Side-outlet tees, with outlet at 90 deg or any other angle, straight or reducing, carry same dimensions center-to-face and face-to-face as regular tees having same reductions.
- (11) In a side-outlet tee, the larger of the two side outlets governs the center-to-face dimension *J*.

Table I-4 Dimensions of Class 125 Gray Iron Flanged Fittings

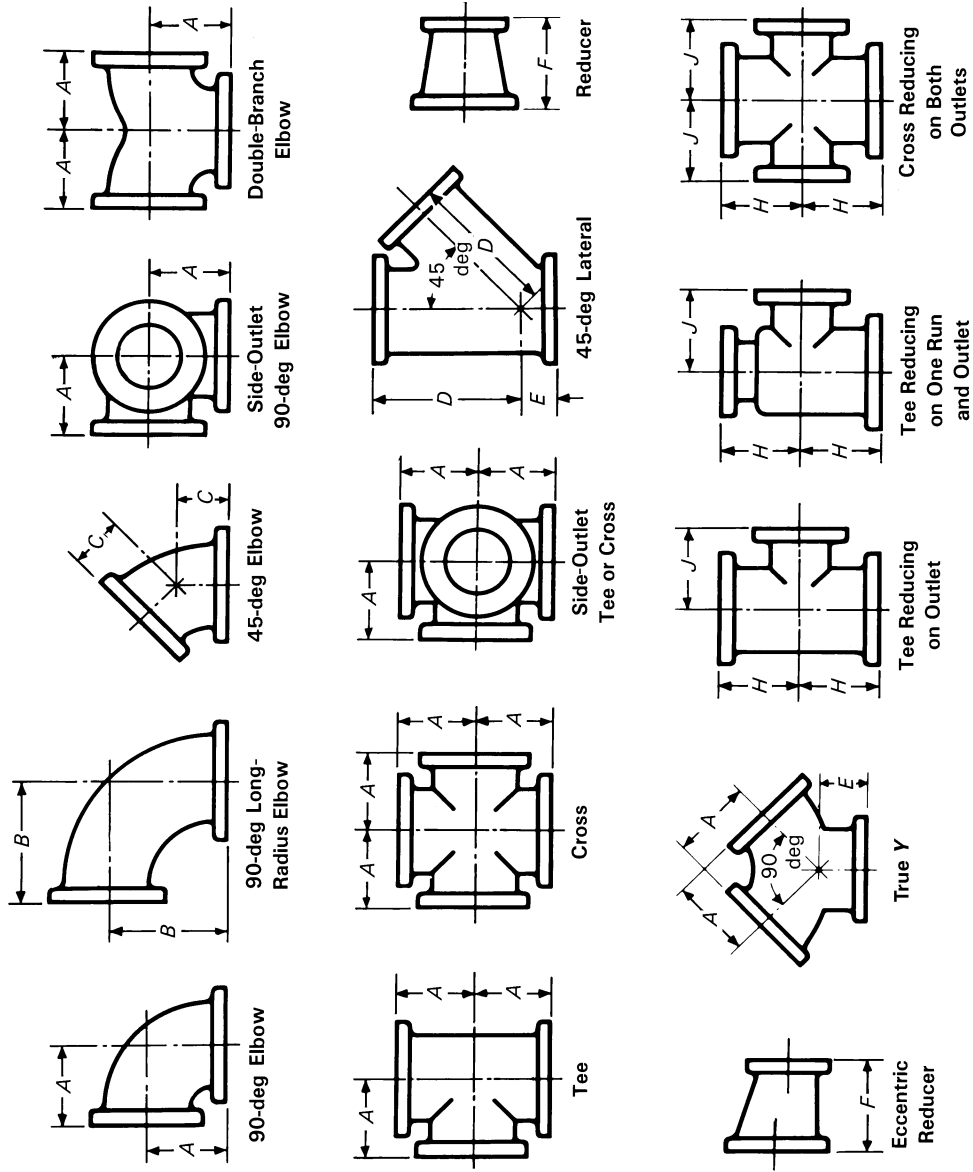

Table I-4 Dimensions of Class 125 Gray Iron Flanged Fittings (Cont'd)

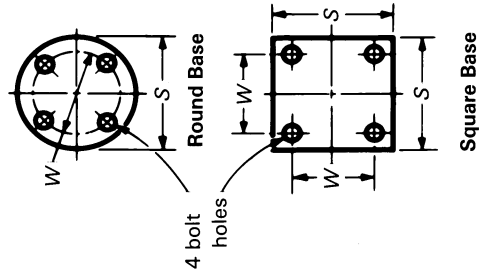
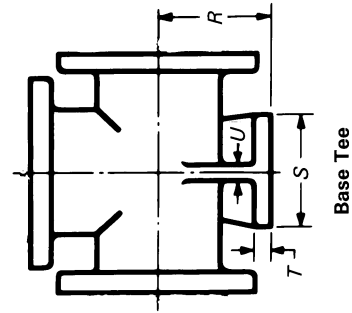
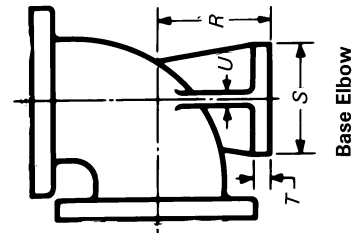
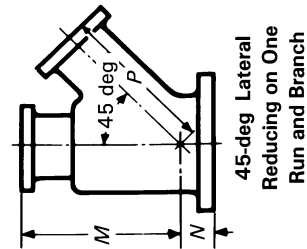
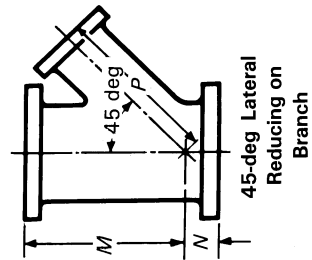
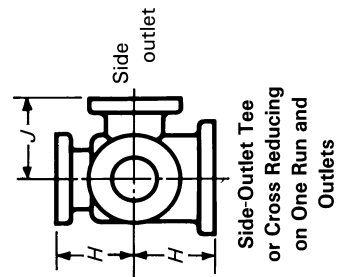
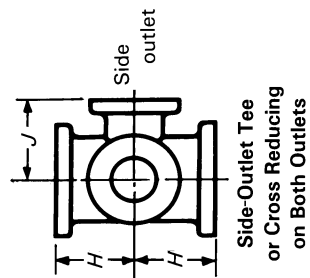
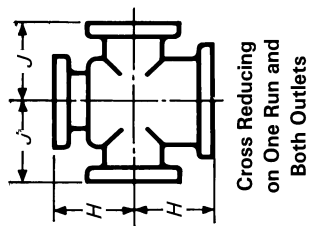

Table I-4 Dimensions of Class 125 Gray Iron Flanged Fittings (Cont'd)

NPS	Straight Fittings [Notes (5) and (6)]											Reducing Fittings (Short-Body Patterns) [Notes (11) and (12)]		
	Center-to-Face 90-deg Elbow, Tees, Crosses, True, Y, and Double-Branch Elbow, A				Center-to-Face 90-deg Long-Radius Elbow, B	Center-to-Face 45-deg Elbow, C	Center-to-Face True, Y and Lateral, D	Short Center-to-Face True, Y and Lateral, E	Face-to-Face Reducer, F	NPS Size of Outlet and Smaller	Center-to-Face Run, H	Center-to-Face Outlet or Side Outlet, J	Tees and Crosses	
	Flanges [Notes (1)-(3)]		General										Notes (6)-(9)	
Diameter of Flange	Minimum Thickness of Flange	Inside Diameter of Fittings	Wall Thickness	Notes (6)-(9)	Notes (6)-(8)	Notes (9)	Notes (9)	Notes (10)	Notes (6) and (10)	H	J			
1	4.25	0.44	1.00	0.31	3.50	5.00	1.75	5.75	1.75	
1 1/4	4.62	0.50	1.25	0.31	3.75	5.50	2.00	6.25	1.75	
1 1/2	5.00	0.56	1.50	0.31	4.00	6.00	2.25	7.00	2.00	
2	6.00	0.62	2.00	0.31	4.50	6.50	2.50	8.00	2.50	5.0	5.0	5.0	5.0	
2 1/2	7.00	0.69	2.50	0.31	5.00	7.00	3.00	9.50	2.50	5.5	5.5	5.5	5.5	
3	7.50	0.75	3.00	0.38	5.50	7.75	3.00	10.00	3.00	6.0	6.0	6.0	6.0	
3 1/2	8.50	0.81	3.50	0.44	6.00	8.50	3.50	11.50	3.00	6.5	6.5	6.5	6.5	
4	9.00	0.94	4.00	0.50	6.50	9.00	4.00	12.00	3.00	7.0	7.0	7.0	7.0	
5	10.00	0.94	5.00	0.50	7.50	10.25	4.50	13.50	3.50	8.0	8.0	8.0	8.0	
6	11.00	1.00	6.00	0.56	8.00	11.50	5.00	14.50	3.50	9.0	9.0	9.0	9.0	
8	13.50	1.12	8.00	0.62	9.00	14.00	5.50	17.50	4.50	11.0	11.0	11.0	11.0	
10	16.00	1.19	10.00	0.75	11.00	16.50	6.50	20.50	5.00	12.0	12.0	12.0	12.0	
12	19.00	1.25	12.00	0.81	12.00	19.00	7.50	24.50	5.50	14.0	14.0	14.0	14.0	
14	21.00	1.38	14.00	0.88	14.00	21.50	7.50	27.00	6.00	16.0	16.0	16.0	16.0	
16	23.50	1.44	16.00	1.00	15.00	24.00	8.00	30.00	6.50	18.0	18.0	18.0	18.0	
18	25.00	1.56	18.00	1.06	16.50	26.50	8.50	32.00	7.00	19.0	19.0	19.0	19.0	
20	27.50	1.69	20.00	1.12	18.00	29.00	9.50	35.00	8.00	20.0	20.0	20.0	20.0	
24	32.00	1.88	24.00	1.25	22.00	34.00	11.00	40.50	9.00	24.0	24.0	24.0	24.0	
30	38.75	2.12	30.00	1.44	25.00	41.50	15.00	49.00	10.00	30.0	30.0	30.0	30.0	
36	46.00	2.38	36.00	1.62	28.00	49.00	18.00	36.0	36.0	36.0	36.0	
42	53.00	2.62	42.00	1.81	31.00	56.50	21.00	42.0	42.0	42.0	42.0	
48	59.50	2.75	48.00	2.00	34.00	64.00	24.00	48.0	48.0	48.0	48.0	

Table I-4 Dimensions of Class 125 Gray Iron Flanged Fittings (Cont'd)

Reducing Fittings (Short-Body Patterns) [Notes (11) and (12)]				Base Elbows and Tees [Notes (15)–(17)]					
NPS Size of Branch and Smaller	Laterals [Note (9)]			Diameter of Round Base or Width of Square Base, S [Notes (18) and (19)]	Thickness of Base, T	Thickness of Ribs, U	NPS Size of Supporting Pipe for Base	Base Drilling	
	Center- to- Face Run, M	Center- to- Face Run, N	Center- to- Face Branch, P					Center- to- Base, R	Bolt Circle or Bolt Spacing, W
1				3.50	0.44	0.38	3/4	2.75	5/8
1 1/4				3.62	0.44	0.38	3/4	2.75	5/8
1 1/2				3.75	0.44	0.50	1	3.12	5/8
2				4.12	0.50	0.50	1 1/4	3.50	5/8
2 1/2				4.50	0.50	0.50	1 1/4	3.50	5/8
3				4.88	0.56	0.50	1 1/2	3.88	5/8
3 1/2				5.25	0.56	0.50	1 1/2	3.88	5/8
4				5.50	0.62	0.50	2	4.25	3/4
5				6.25	0.69	0.62	2 1/2	5.50	3/4
6				7.00	0.69	0.62	2 1/2	5.50	3/4
8				8.75	0.94	0.88	4	7.50	3/4
10				9.75	0.94	0.88	4	7.50	3/4
12				11.25	1.00	1.00	6	9.50	7/8
14				12.50	1.00	1.00	6	9.50	7/8
16				13.75	1.00	1.00	6	9.50	7/8
8	25.0	1.0	27.5	15.00	1.12	1.12	8	11.75	7/8
10	27.0	1.0	29.5	16.00	1.12	1.12	8	11.75	7/8
12	31.5	0.5	34.5	18.50	1.12	1.12	8	11.75	7/8
14	39.0	0.0	42.0

All reducing laterals NPS 16 and smaller shall have the same center-to-face dimensions as straight-size fittings, corresponding to the size of the largest opening.

Table I-4 Dimensions of Class 125 Gray Iron Flanged Fittings (Cont'd)

GENERAL NOTE: Dimensions are in inches.

NOTES:

- (1) For facing, see para. 7.2(a).
- (2) For flange bolt holes, refer to Table I-9 and para. 7.6.
- (3) For spot facing, see para. 7.7.
- (4) For wall thickness tolerances, see para. 7.1.
- (5) For center-to-face tolerances, see para. 7.4.
- (6) For intersecting centerlines of side-outlet fittings, see para. 7.3.1.
- (7) For center-to-face dimensions of reducing elbows and side-outlet elbows, see paras. 7.3.2(b) and (c).
- (8) For center-to-face dimensions of special degree elbows, see para. 7.3.2(d).
- (9) For reinforcement of crosses and laterals, see para. 7.9.
- (10) For face-to-face dimensions of reducers and eccentric reducers, see para. 7.3.5.
- (11) For center-to-face dimensions of tees and crosses having outlets and laterals having branches larger than given above, see para. 7.3.3(b).
- (12) For center-to-face dimensions of tees, crosses, and laterals reducing on run only, see para. 7.3.3(b).
- (13) For center-to-face dimensions of tees reducing on both runs, known as bull-head tees, see para. 7.3.3(b).
- (14) For center-to-face dimensions of reducing side-outlet tees and crosses having two different size reductions on the outlets, see para. 7.3.3(b).
- (15) Bases are furnished only when specified by the purchaser.
- (16) For tees larger than NPS 24, anchorage fittings are recommended. See Table I-6.
- (17) The base dimension applies to all straight and reducing sizes.
- (18) For reducing fittings, the size and center-to-face dimensions of base are determined by the size of the largest opening of the fitting. In the case of reducing base elbows, orders shall specify whether the base shall be opposite the larger or smaller opening.
- (19) Bolt hole template shown for round base is the same as for the flange of the supporting pipe size, except using only four holes in all cases so placed as to straddle centerlines. The bases of these fittings are intended for support in compression and are not to be used for anchors or supports in tension or shear.

Table I-5 Dimensions of Class 250 Gray Iron Flanged Fittings

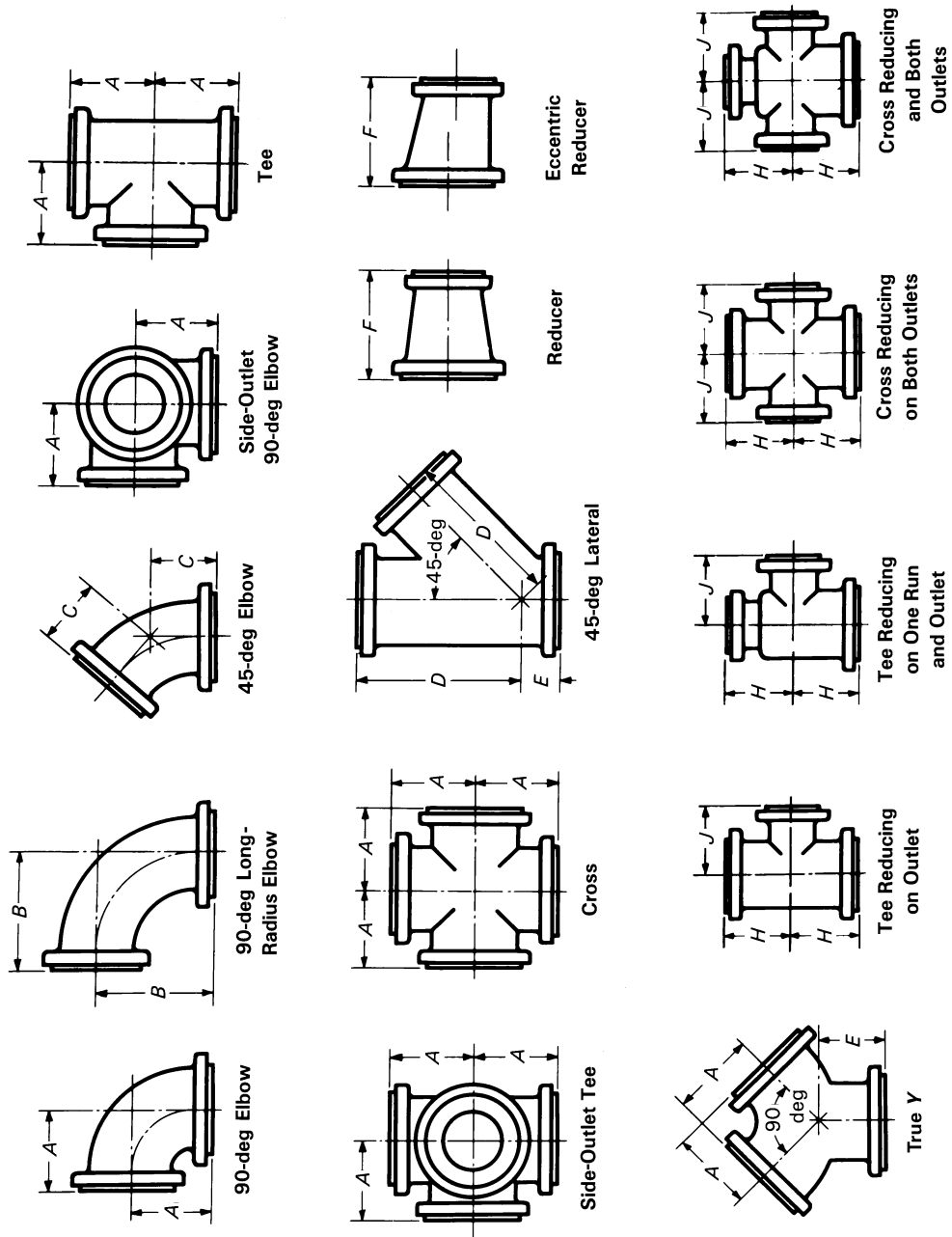

Table I-5 Dimensions of Class 250 Gray Iron Flanged Fittings (Cont'd)

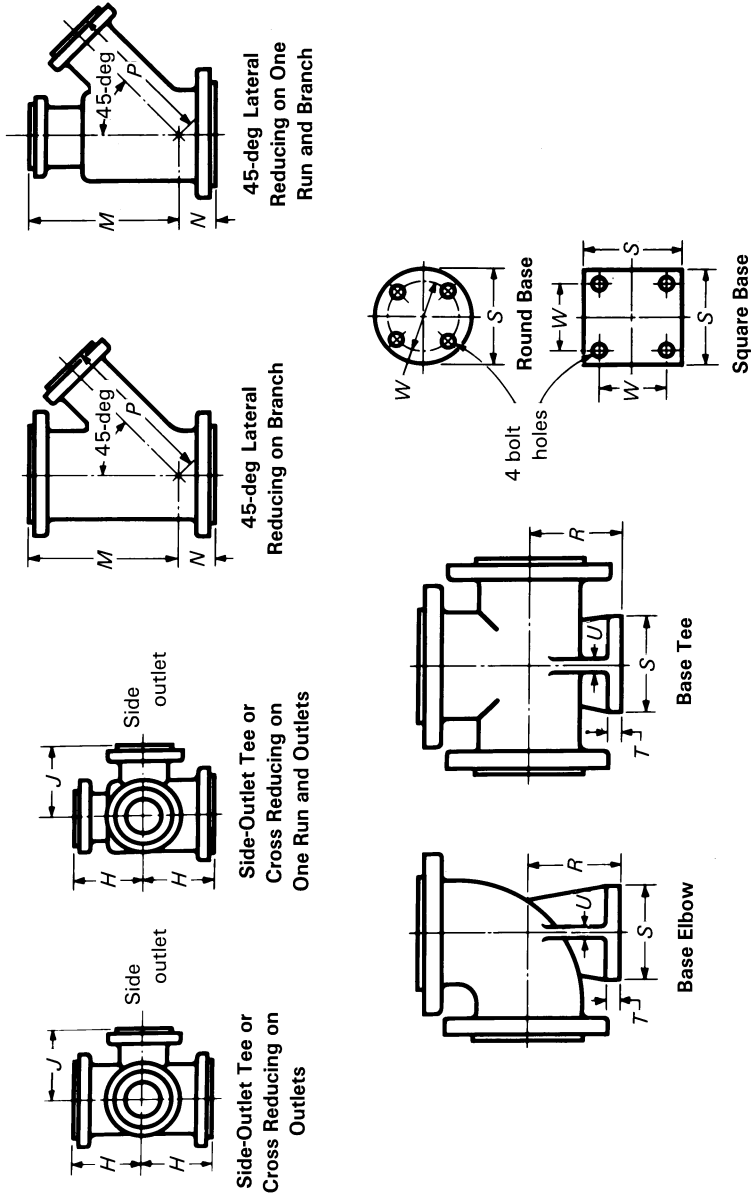

Table I-5 Dimensions of Class 250 Gray Iron Flanged Fittings (Cont'd)

NPS	Flanges [Notes (1)–(3)]			General Fittings [Notes (5) and (6)]				Straight Fittings [Notes (5) and (6)]				Reducing (Short Body) [Notes (11) and (15)]				
	Diameter of Flange	Minimum Thickness of Flange, <i>Q</i>	Diameter of Raised Face [Note (4)]	Inside Diameter of Fittings	Body Wall Thickness	Center-to-Face 90-deg Elbow, Tees, Crosses, and True, <i>Y</i> , [Notes (8)–(10)]	Center-to-90-deg Long-Radius Elbow, <i>B</i> [Notes (6), (8), and (9)]	Center-to-Face 45-deg Elbow, <i>C</i> [Note (9)]	Center-to-Face Lateral, <i>D</i> [Notes (10) and (11)]	Short Center-to-Face True, <i>Y</i> and Lateral, <i>E</i> [Notes (10) and (11)]	Face-to-Face Reducer, <i>F</i> [Note (12)]	NPS Size of Outlet and Smaller [Notes (6) and (12)]	Center-to-Face Outlet or Side Outlet, <i>J</i>	Tees and Crosses [Notes (10), (13), and (14)]		
														Center-to-Face Run, <i>H</i>	Center-to-Face Outlet, <i>J</i>	
1	4.88	0.69	2.69	1.00	0.44	4.00	5.00	2.00	6.50	2.00	...					
1 1/4	5.25	0.75	3.06	1.25	0.44	4.25	5.50	2.50	7.25	2.25	...					
1 1/2	6.12	0.81	3.56	1.50	0.44	4.50	6.00	2.75	8.50	2.50	...					
2	6.50	0.88	4.19	2.00	0.44	5.00	6.50	3.00	9.00	2.50	5.0					
2 1/2	7.50	1.00	4.94	2.50	0.50	5.50	7.00	3.50	10.50	2.50	5.5					
3	8.25	1.12	5.69	3.00	0.56	6.00	7.75	3.50	11.00	3.00	6.0					
3 1/2	9.00	1.19	6.31	3.50	0.56	6.50	8.50	4.00	12.50	3.00	6.5					
4	10.00	1.25	6.94	4.00	0.62	7.00	9.00	4.50	13.50	3.00	7.0					
5	11.00	1.38	8.31	5.00	0.69	8.00	10.25	5.00	15.00	3.50	8.0					
6	12.50	1.44	9.69	6.00	0.75	8.50	11.50	5.50	17.50	4.00	9.0					
8	15.00	1.62	11.94	8.00	0.81	10.00	14.00	6.00	20.50	5.00	11.0					
10	17.50	1.88	14.06	10.00	0.94	11.50	16.50	7.00	24.00	5.50	12.0					
12	20.50	2.00	16.44	12.00	1.00	13.00	19.00	8.00	27.50	6.00	14.0					
14	23.00	2.12	18.94	13.25	1.12	15.00	21.50	8.50	31.00	6.50	16.0					
16	25.50	2.25	21.06	15.25	1.25	16.50	24.00	9.50	34.50	7.50	18.0					
18	28.00	2.38	23.31	17.00	1.38	18.00	26.50	10.00	37.50	8.00	19.0			12	14.0	17.0
20	30.50	2.50	25.56	19.00	1.50	19.50	29.00	10.50	40.50	8.50	20.0			14	15.5	18.5
24	36.00	2.75	30.31	23.00	1.62	22.50	34.00	12.00	47.50	10.00	24.0			16	17.0	21.5
30	43.00	3.00	37.19	29.00	2.00	27.50	41.50	15.00	30.0			20	20.5	25.5

All reducing tees and crosses NPS 16 and smaller shall have the same center-to-face dimensions as straight-size fittings, corresponding to the size of the largest opening.

Table I-5 Dimensions of Class 250 Gray Iron Flanged Fittings (Cont'd)

		Reducing (Short Body) [Notes (11) and (15)]				Base, Elbows, and Tees [Notes (16)–(18)]				
		Laterals [Note (10)]				Diameter of Round Base or Width of Square Base, <i>S</i> [Note (19)]				
NPS	NPS Size of Branch and Smaller	Center-Face Run, <i>M</i>	Center-Face Run, <i>N</i>	Center-Face Branch, <i>P</i>	Center-to-Base, <i>R</i>	Thickness of Base, <i>T</i>	Thickness of Ribs, <i>U</i>	NPS Size of Supporting Pipe for Base	Base Drilling [Note (20)] Bolt Circle or Bolt Spacing, <i>W</i>	Diameter of Holes
2					4.50	0.75	0.50	1 1/4	3.88	3/4
2 1/2					4.75	0.75	0.50	1 1/4	3.88	3/4
3					5.25	0.81	0.62	1 1/2	4.50	7/8
3 1/2					5.62	0.81	0.62	1 1/2	4.50	7/8
4					6.00	0.88	0.62	2	5.00	3/4
5					6.75	1.00	0.75	2 1/2	5.88	7/8
6					7.50	1.00	0.75	2 1/2	5.88	7/8
8					9.00	1.25	0.88	4	7.88	7/8
10					10.50	1.25	0.88	4	7.88	7/8
12					12.00	1.44	1.00	6	10.62	7/8
14					13.50	1.44	1.00	6	10.62	7/8
16					14.75	1.44	1.12	6	10.62	7/8
18					16.25	1.62	1.12	8	13.00	1
20					17.88	1.62	1.25	8	13.00	1
24					20.75	1.88	1.25	10	15.25	1 1/8

Table I-5 Dimensions of Class 250 Gray Iron Flanged Fittings (Cont'd)

GENERAL NOTE: Dimensions are in inches.

NOTES:

- (1) For facing, see para. 7.2(b).
- (2) For flange bolt holes, refer to Table I-2 and para. 7.6.
- (3) For spot facing, see para. 7.7.
- (4) Tolerance of the diameter of the raised face is equal to ± 0.03 in.
- (5) For center-to-face tolerances, see para. 7.4.
- (6) For intersecting centerlines of side-outlet fittings, see para. 7.3.1.
- (7) For wall thickness tolerances, see para. 7.1.
- (8) For center-to-face dimensions of reducing elbows and side-outlet elbows, see paras. 7.3.2(b) and (c).
- (9) For center-to-face dimensions of special degree elbows, see para. 7.3.2(d).
- (10) For reinforcement of crosses and laterals, see para. 7.8.
- (11) For center-to-face dimensions of tees and crosses having outlets and laterals having branches larger than given above, see para. 7.3.3(b).
- (12) For face-to-face dimensions of reducers and eccentric reducers, see para. 7.3.5.
- (13) For center-to-face dimensions of tees reducing on both runs, known as bull-head tees, see para. 7.3.3(c).
- (14) For center-to-face dimensions of reducing side-outlet tees and crosses having two different size reductions on the outlet, see para. 7.3.3(b).
- (15) For center-to-face dimensions of tees, crosses, and laterals reducing on run only, see para. 7.3.3(b).
- (16) Bases are furnished only when specified by purchaser.
- (17) The base dimensions apply to all straight and reducing sizes.
- (18) For tees larger than NPS 24, anchorage fittings are recommended. See Table I-7.
- (19) For reducing fittings, the size and center-to-face dimensions of base are determined by the size of the largest opening of the fitting. In the case of reducing base elbows, orders shall specify whether the base shall be opposite the larger or smaller opening.
- (20) Bolt hole template shown for round base is the same as for the flange of the supporting pipe size, except using only four holes in all cases so placed as to straddle centerlines. The bases of these fittings are intended for support in compression and are not to be used for anchors or supports in tension or shear.

Table I-6 Dimensions of Anchorage Bases for Straight and Reducing Class 125 Tees

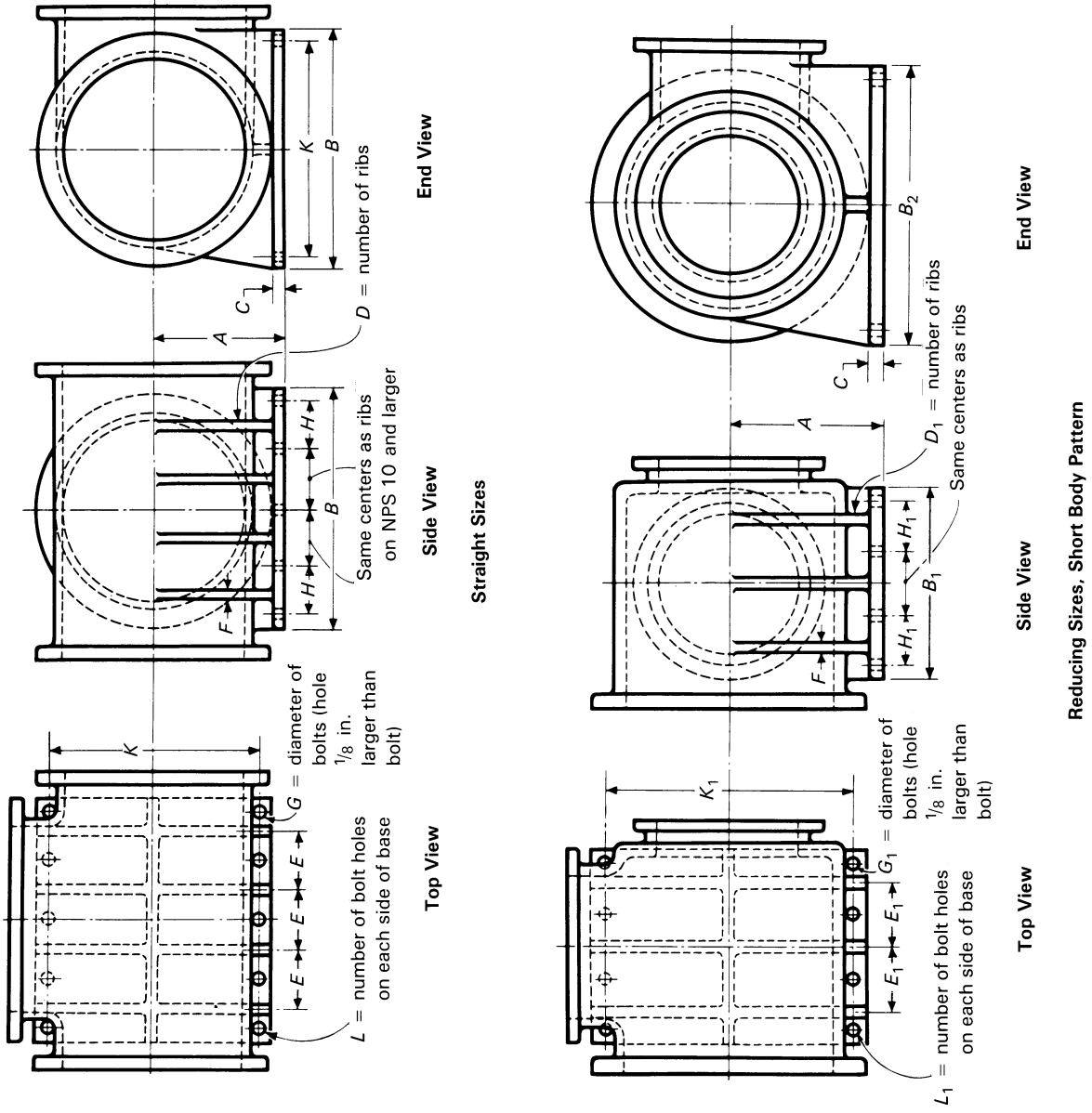

Table I-7 Dimensions of Anchorage Bases for Straight and Reducing Class 250 Tees

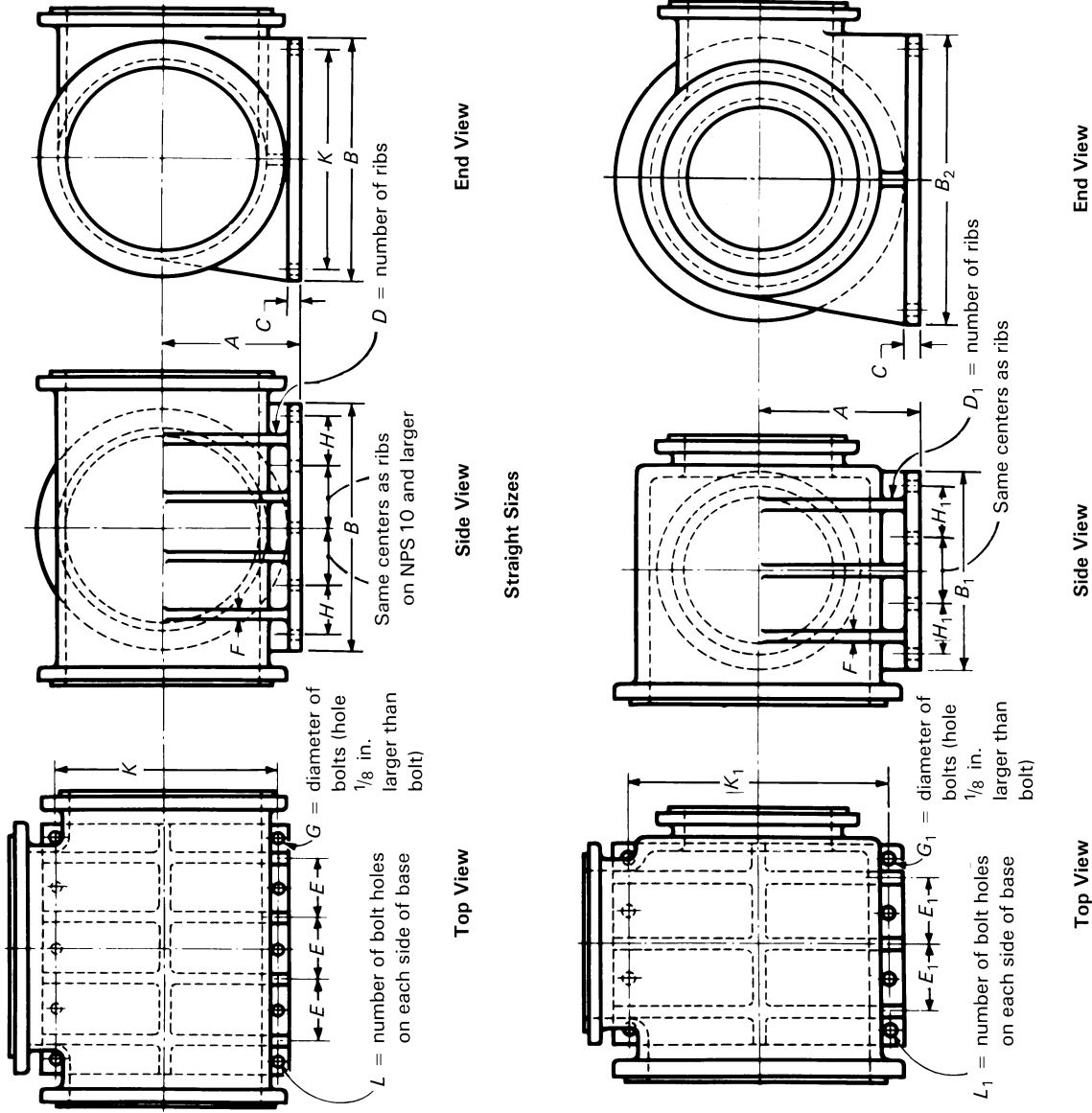

Table I-7 Dimensions of Anchorage Bases for Straight and Reducing Class 250 Tees (Cont'd)

NPS	Common on Both Straight Sizes and Reducing Sizes										Straight Sizes					Reducing Sizes (Short-Body Pattern) [Notes (2) and (3)]																	
	Center-to-Base, A		Thickness of Base, C		Diameter of Bolts, G		Thickness of Ribs, F		Width and Length of Square Base, B		Transverse Bolt Centers, K		Number of Bolt Holes on Each Side of Base, L		Number of Ribs, D		Centers of Ribs, E		Longitudinal Center From End Bolt to Second Bolt, H		NPS Outlet Sizes and Smaller		Length of Base, B ₁		Centers of Ribs, E ₁		Longitudinal Center From End Bolt to Second Bolt, H ₁		Transverse Bolt Centers, K ₁		Width of Base, B ₂		
	A	C	G	F	B	K	L	D	E	H	Smaller	E ₁	H ₁	K ₁	B ₁	E ₁	H ₁	K ₁	B ₂														
2½	4.75	0.75	5/8	0.56	7.50	5.75	2	1	...	5.75	2	1	...	5.75	2	1	...	5.75	2	1	...	5.75	2	1	...	5.75	2	1	...	5.75	2	1	...
3	5.25	0.81	5/8	0.56	8.25	6.50	2	1	...	6.50	2	1	...	6.50	2	1	...	6.50	2	1	...	6.50	2	1	...	6.50	2	1	...	6.50	2	1	...
3½	5.62	0.94	5/8	0.56	9.00	7.25	2	1	...	7.25	2	1	...	7.25	2	1	...	7.25	2	1	...	7.25	2	1	...	7.25	2	1	...	7.25	2	1	...
4	6.00	0.94	5/8	0.62	10.00	7.75	3	2	4	3.78	3	2	4	3.78	3	2	4	3.78	3	2	4	3.78	3	2	4	3.78	3	2	4	3.78	3	2	4
5	6.75	1.00	7/8	0.69	11.00	8.75	3	2	5	4.38	3	2	5	4.38	3	2	5	4.38	3	2	5	4.38	3	2	5	4.38	3	2	5	4.38	3	2	5
6	7.50	1.06	7/8	0.75	12.50	10.25	3	2	6	5.12	3	2	6	5.12	3	2	6	5.12	3	2	6	5.12	3	2	6	5.12	3	2	6	5.12	3	2	6
8	9.00	1.12	1	0.81	15.00	12.50	3	2	8	6.25	3	2	8	6.25	3	2	8	6.25	3	2	8	6.25	3	2	8	6.25	3	2	8	6.25	3	2	8
10	10.50	1.25	1 1/8	0.94	17.50	14.75	4	3	5	4.88	4	3	5	4.88	4	3	5	4.88	4	3	5	4.88	4	3	5	4.88	4	3	5	4.88	4	3	5
12	12.00	1.25	1 1/4	1.00	20.50	17.50	4	3	6	5.75	4	3	6	5.75	4	3	6	5.75	4	3	6	5.75	4	3	6	5.75	4	3	6	5.75	4	3	6
14	13.50	1.38	1 1/4	1.12	23.00	20.00	4	3	7	6.50	4	3	7	6.50	4	3	7	6.50	4	3	7	6.50	4	3	7	6.50	4	3	7	6.50	4	3	7
16	14.75	1.56	1 3/8	1.25	25.50	22.00	4	3	8	7.00	4	3	8	7.00	4	3	8	7.00	4	3	8	7.00	4	3	8	7.00	4	3	8	7.00	4	3	8
18	16.25	1.69	1 3/8	1.38	28.00	24.25	4	3	9	7.38	4	3	9	7.38	4	3	9	7.38	4	3	9	7.38	4	3	9	7.38	4	3	9	7.38	4	3	9
20	17.88	1.88	1 1/2	1.50	30.50	26.75	4	3	10	8.38	4	3	10	8.38	4	3	10	8.38	4	3	10	8.38	4	3	10	8.38	4	3	10	8.38	4	3	10
24	20.75	2.06	1 5/8	1.62	36.00	31.75	4	3	12	9.88	4	3	12	9.88	4	3	12	9.88	4	3	12	9.88	4	3	12	9.88	4	3	12	9.88	4	3	12
30	24.75	2.31	1 3/4	2.00	43.00	38.00	5	4	10	9.00	5	4	10	9.00	5	4	10	9.00	5	4	10	9.00	5	4	10	9.00	5	4	10	9.00	5	4	10

Reducing tee sizes NPS 16 and smaller shall have the same base (B) dimensions as a straight-size tee, corresponding to the size of the largest opening.

GENERAL NOTES:

- (a) Dimensions are in inches.
- (b) For tee dimensions, refer to Table I-5.

NOTES:

- (1) Bases are furnished only when specified by the purchaser.
- (2) For NPS 18 and larger, if the outlet is the same size or smaller than given for reducing tees, the base dimensions as shown in this Table for reducing tees shall be used. If the outlet is larger than shown for reducing tees, the base dimensions shall be the same as for the straight-size tees, corresponding to the size of the largest opening.
- (3) Tees reducing on run only shall have the same base dimensions as straight-size tees, corresponding to the size of the largest opening.

Table I-8 Class 25 Flange and Bolting Dimensions

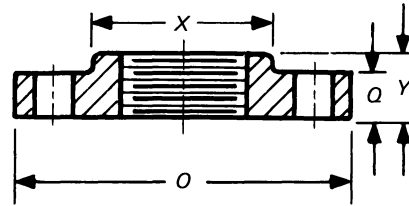

NPS	Flanges		Hub		Bolt Holes		Bolting [Note (6)]		
	Diameter, O	Minimum Thickness, Q [Notes (1) and (2)]	Minimum Diameter, X	Minimum Length, Y	Diameter of Bolt Circle [Note (3)]	Diameter of Bolt Holes [Notes (3)–(5)]	Number of Bolts	Diameter of Bolts [Note (3)]	Length of Bolts
4	9.00	0.75	5.31	1.31	7.50	$\frac{3}{4}$	8	$\frac{5}{8}$	2.50
5	10.00	0.75	6.44	1.44	8.50	$\frac{3}{4}$	8	$\frac{5}{8}$	2.50
6	11.00	0.75	7.56	1.56	9.50	$\frac{3}{4}$	8	$\frac{5}{8}$	2.50
8	13.50	0.75	9.69	1.75	11.75	$\frac{3}{4}$	8	$\frac{5}{8}$	2.50
10	16.00	0.88	11.94	1.94	14.25	$\frac{3}{4}$	12	$\frac{5}{8}$	3.00
12	19.00	1.00	14.06	2.19	17.00	$\frac{3}{4}$	12	$\frac{5}{8}$	3.00
14	21.00	1.12	15.37	2.25	18.75	$\frac{7}{8}$	12	$\frac{3}{4}$	3.50
16	23.50	1.12	17.50	2.50	21.25	$\frac{7}{8}$	16	$\frac{3}{4}$	3.50
18	25.00	1.25	19.62	2.69	22.75	$\frac{7}{8}$	16	$\frac{3}{4}$	4.00
20	27.50	1.25	21.75	2.88	25.00	$\frac{7}{8}$	20	$\frac{3}{4}$	4.00
24	32.00	1.38	26.00	3.25	29.50	$\frac{7}{8}$	20	$\frac{3}{4}$	4.00
30	38.75	1.50	36.00	1	28	$\frac{7}{8}$	4.50
36	46.00	1.62	42.75	1	32	$\frac{7}{8}$	5.00
42	53.00	1.75	49.50	$1\frac{1}{8}$	36	1	5.50
48	59.50	2.00	56.00	$1\frac{1}{8}$	44	1	6.00
54	66.25	2.25	62.75	$1\frac{1}{8}$	44	1	6.50
60	73.00	2.25	69.25	$1\frac{1}{4}$	52	$1\frac{1}{8}$	6.50
72	86.50	2.50	82.50	$1\frac{1}{4}$	60	$1\frac{1}{8}$	7.00
84	99.75	2.75	95.50	$1\frac{3}{8}$	64	$1\frac{1}{4}$	7.50
96	113.25	3.00	108.50	$1\frac{3}{8}$	68	$1\frac{1}{4}$	8.00

GENERAL NOTE: Dimensions are in inches.

NOTES:

- (1) For facing, see para. 7.2(a).
- (2) Threaded companion flanges should not be thinner than the Class 125 thickness on NPS 24 and smaller. Other types of flanges may have thicknesses as given above.
- (3) The flange diameter, bolt circle, and number of bolts are the same in Class 25 as in Class 125. Bolt hole diameters of Class 25 shall not be modified when mated with Class 125 flanges or with steel flanges.
- (4) For spot facing, see para 7.7.
- (5) For flange bolt holes, see para. 7.6.
- (6) For bolts and nuts, see para. 8.1.

Table I-9 Class 125 Flange and Bolting Dimensions

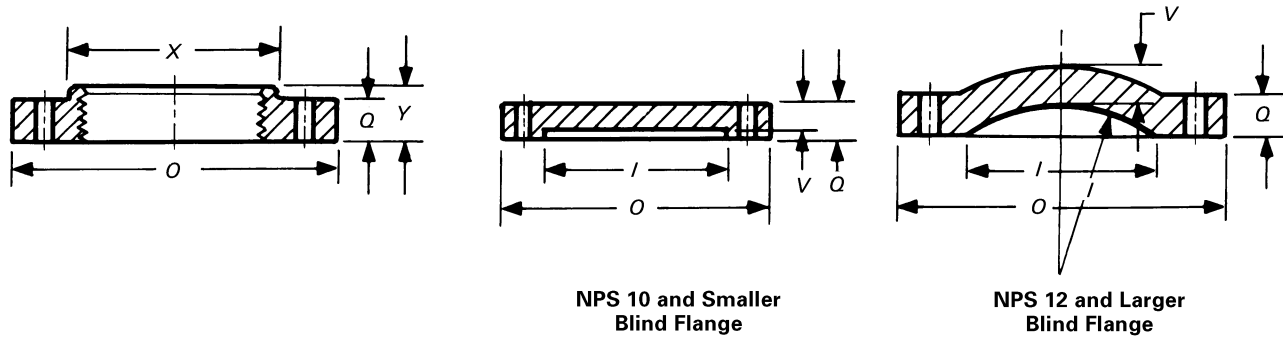

NPS	Flanges		Hub		Blind Flanges		Bolt Holes		Bolting			
	Diameter of Flange, O	Minimum Thickness of Flange, Q [Note (1)]	Minimum Diameter, X	Minimum Length of Hub and Threads, Y [Note (2)]	Diameter of Port, I [Note (3)]	Wall Thickness, V [Note (4)]	Diameter of Bolt Circle	Diameter of Bolt Holes [Notes (5) and (6)]	Number of Bolts	Diameter of Bolts	Length of Bolt [Notes (7) and (8)]	Length of Bolt Stud With Two Nuts [Note (7)]
1	4.25	0.44	1.94	0.69	1.00	0.38	3.12	5/8	4	1/2	2.00	...
1 1/4	4.62	0.50	2.31	0.81	1.25	0.44	3.50	5/8	4	1/2	2.00	...
1 1/2	5.00	0.56	2.56	0.88	1.50	0.50	3.88	5/8	4	1/2	2.00	...
2	6.00	0.62	3.06	1.00	2.00	0.56	4.75	3/4	4	5/8	2.50	...
2 1/2	7.00	0.69	3.56	1.12	2.50	0.63	5.50	3/4	4	5/8	2.50	...
3	7.50	0.75	4.25	1.19	3.00	0.69	6.00	3/4	4	5/8	2.50	...
3 1/2	8.50	0.81	4.81	1.25	3.50	0.75	7.00	3/4	8	5/8	3.00	...
4	9.00	0.94	5.31	1.31	4.00	0.88	7.50	3/4	8	5/8	3.00	...
5	10.00	0.94	6.44	1.44	5.00	0.88	8.50	7/8	8	3/4	3.00	...
6	11.00	1.00	7.56	1.56	6.00	0.94	9.50	7/8	8	3/4	3.50	...
8	13.50	1.12	9.69	1.75	8.00	1.06	11.75	7/8	8	3/4	3.50	...
10	16.00	1.19	11.94	1.94	10.00	1.12	14.25	1	12	7/8	4.00	...
12	19.00	1.25	14.06	2.19	12.00	0.81	17.00	1	12	7/8	4.00	...
14	21.00	1.38	15.38	2.25	14.00	0.88	18.75	1 1/8	12	1	4.50	...
16	23.50	1.44	17.50	2.50	16.00	1.00	21.25	1 1/8	16	1	4.50	...
18	25.00	1.56	19.62	2.69	18.00	1.06	22.75	1 1/4	16	1 1/8	5.00	...
20	27.50	1.69	21.75	2.88	20.00	1.12	25.00	1 1/4	20	1 1/8	5.00	...
24	32.00	1.88	26.00	3.25	24.00	1.25	29.50	1 3/8	20	1 1/4	5.50	...
30	38.75	2.12	30.00	1.44	36.00	1 3/8	28	1 1/4	6.50	...
36	46.00	2.38	36.00	1.62	42.75	1 7/8	32	1 1/2	7.00	9.00
42	53.00	2.62	42.00	1.81	49.50	1 7/8	36	1 1/2	7.50	9.50
48	59.50	2.75	48.00	2.00	56.00	1 7/8	44	1 1/2	8.00	9.50
54 (9)	66.25	3.00	62.75	2	44	1 3/4	8.50	10.50
60 (9)	73.00	3.12	69.25	2	52	1 3/4	9.00	11.00
72 (9)	86.50	3.50	82.50	2	60	1 3/4	9.50	11.50
84 (9)	99.75	3.88	95.50	2 1/4	64	2	10.50	13.00
96 (9)	113.25	4.25	108.50	2 1/2	68	2 1/4	11.50	14.00

GENERAL NOTE: Dimensions are in inches.

NOTES:

- (1) For facing, see para. 7.2(a).
- (2) For thread of threaded flanges, see paras. 7.5.1 and 7.5.2.
- (3) All blind flanges NPS 12 and larger must be dished with inside radius equal to the port diameter.
- (4) For wall thickness tolerance, see para. 7.1.
- (5) For flange bolt holes, see para. 7.6.
- (6) For spot facing, see para. 7.7.
- (7) For bolts and nuts, see para. 8.1.
- (8) Bolt lengths to be compensated for when bolting steel to cast iron flanges.
- (9) NPS 54 through 96 are included for convenience. Pressure-temperature ratings are the user's responsibility.

Table I-10 Minimum Thread Length

Tap Size, NPS	Thread Length, A, in.
$\frac{3}{8}$	0.41
$\frac{1}{2}$	0.53
$\frac{3}{4}$	0.55
1	0.68
$1\frac{1}{4}$	0.71
$1\frac{1}{2}$	0.72
2	0.76

MANDATORY APPENDIX II REFERENCES

(15)

The following is a list of publications referenced in this Standard. Unless otherwise specified, the latest edition shall apply:

ASME B1.1, Unified Inch Screw Threads (UN and UNR Thread Form)

ASME B1.20.1, Pipe Threads, General Purpose (Inch)

ASME B16.5, Pipe Flanges and Flanged Fittings: NPS $\frac{1}{2}$ Through NPS 24 Metric/Inch Standard

ASME B16.21, Nonmetallic Flat Gaskets for Pipe Flanges
ASME B18.2.1, Square and Hex Bolts and Screws (Inch Series)

ASME B18.2.2, Square and Hex Nuts (Inch Series)

ASME PCC-1, Guidelines for Pressure Boundary Bolted Flange Joint Assembly

Publisher: The American Society of Mechanical Engineers (ASME), Two Park Avenue, New York, NY 10016-5990 (www.asme.org)

ASTM A 126-04 (2014), Specification for Gray Iron Castings for Valves, Flanges, and Pipe Fittings

ASTM A 307-14, Specification for Carbon Steel Bolts and Studs, 60,000 psi Tensile Strength

ASTM E 29-13 Standard Practice for Using Significant Digits in Test Data to Determine Conformance With Specifications

Publisher: American Society for Testing and Materials (ASTM International), 100 Barr Harbor Drive, P.O. Box C700, West Conshohocken, PA 19428-2959 (www.astm.org)

ISO 9001: 2008, Quality management systems — Requirements¹

Publisher: International Organization for Standardization (ISO), Central Secretariat, Chemin de Blandonnet 8, Case Postale 401, 1214 Vernier, Geneva, Switzerland (www.iso.org)

MSS SP-6-2012, Standard Finishes for Contact Faces of Pipe Flanges and Connecting-End Flanges of Valves and Fittings

MSS SP-9-2013, Spot Facing for Bronze, Iron, and Steel Flanges

MSS SP-45-2003 (R2008), Bypass and Drain Connections

Publisher: Manufacturers Standardization Society of the Valve and Fittings Industry, Inc. (MSS), 127 Park Street, NE, Vienna, VA 22180 (www.mss-hq.org)

¹ May also be obtained from American National Standards Institute (ANSI), 25 West 43rd Street, New York, NY 10036.

NONMANDATORY APPENDIX A QUALITY SYSTEM PROGRAM

The products manufactured in accordance with this Standard shall be produced under ISO 9001.¹ A determination of the need for registration and/or certification of the product manufacturer's quality system program

¹ ISO 9001 is also available from the American National Standards Institute (ANSI) and the American Society for Quality (ASQ) as American National Standards that are identified by the prefix "Q," replacing the prefix "ISO." ISO 9001 is listed under References in Mandatory Appendix II.

by an independent organization shall be the responsibility of the manufacturer. The detailed documentation demonstrating program compliance shall be available to the purchaser at the manufacturer's facility. A written summary description of the program utilized by the product manufacturer shall be available to the purchaser upon request. The product manufacturer is defined as the entity whose name or trademark appears on the product in accordance with the marking or identification requirements of this Standard.

ASME B16.1-2015

ISBN 978-0-7918-7049-5



9 780791 870495

