

ASME B16.9-2012
(Revision of ASME B16.9-2007)

Factory-Made Wrought Buttwelding Fittings

AN AMERICAN NATIONAL STANDARD



The American Society of
Mechanical Engineers

INTENTIONALLY LEFT BLANK

ASME B16.9-2012
(Revision of ASME B16.9-2007)

Factory-Made Wrought Buttwelding Fittings

AN AMERICAN NATIONAL STANDARD



**The American Society of
Mechanical Engineers**

Two Park Avenue • New York, NY • 10016 USA

Date of Issuance: February 28, 2013

The next edition of this Standard is scheduled for publication in 2017.

ASME issues written replies to inquiries concerning interpretations of technical aspects of this Standard. Periodically certain actions of the ASME B16 Committee may be published as Cases. Cases and interpretations are published on the ASME Web site under the Committee Pages at <http://cstools.asme.org/> as they are issued.

Errata to codes and standards may be posted on the ASME Web site under the Committee Pages to provide corrections to incorrectly published items, or to correct typographical or grammatical errors in codes and standards. Such errata shall be used on the date posted.

The Committee Pages can be found at <http://cstools.asme.org/>. There is an option available to automatically receive an e-mail notification when errata are posted to a particular code or standard. This option can be found on the appropriate Committee Page after selecting "Errata" in the "Publication Information" section.

ASME is the registered trademark of The American Society of Mechanical Engineers.

This code or standard was developed under procedures accredited as meeting the criteria for American National Standards. The Standards Committee that approved the code or standard was balanced to assure that individuals from competent and concerned interests have had an opportunity to participate. The proposed code or standard was made available for public review and comment that provides an opportunity for additional public input from industry, academia, regulatory agencies, and the public-at-large.

ASME does not "approve," "rate," or "endorse" any item, construction, proprietary device, or activity.

ASME does not take any position with respect to the validity of any patent rights asserted in connection with any items mentioned in this document, and does not undertake to insure anyone utilizing a standard against liability for infringement of any applicable letters patent, nor assumes any such liability. Users of a code or standard are expressly advised that determination of the validity of any such patent rights, and the risk of infringement of such rights, is entirely their own responsibility.

Participation by federal agency representative(s) or person(s) affiliated with industry is not to be interpreted as government or industry endorsement of this code or standard.

ASME accepts responsibility for only those interpretations of this document issued in accordance with the established ASME procedures and policies, which precludes the issuance of interpretations by individuals.

No part of this document may be reproduced in any form,
in an electronic retrieval system or otherwise,
without the prior written permission of the publisher.

The American Society of Mechanical Engineers
Two Park Avenue, New York, NY 10016-5990

Copyright © 2013 by
THE AMERICAN SOCIETY OF MECHANICAL ENGINEERS
All rights reserved
Printed in U.S.A.

CONTENTS

Foreword	iv
Committee Roster	v
Correspondence With the B16 Committee	vi
Summary of Changes	vii
1 Scope	1
2 Pressure Ratings	1
3 Size	2
4 Marking	2
5 Material	2
6 Fitting Dimensions	3
7 Surface Contours	3
8 End Preparation	3
9 Design Proof Test	3
10 Production Tests	5
11 Tolerances	5
Figure	
1 Maximum Envelope for Welding End Transitions	6
Tables	
1 Dimensions of Long Radius Elbows	7
2 Dimensions of Long Radius Reducing Elbows	8
3 Dimensions of Long Radius Returns	9
4 Dimensions of Short Radius Elbows	10
5 Dimensions of Short Radius 180-deg Returns	10
6 Dimensions of 3D Elbows	11
7 Dimensions of Straight Tees and Crosses	11
8 Dimensions of Reducing Outlet Tees and Reducing Outlet Crosses	12
9 Dimensions of Lap Joint Stub Ends	15
10 Dimensions of Caps	16
11 Dimensions of Reducers	17
12 Welding Bevels and Root Face	19
13 Tolerances	20
Mandatory Appendices	
I Inch Tables	23
II References	37
Nonmandatory Appendix	
A Quality System Program	38

FOREWORD

In 1921, the American Engineering Standards Committee, later the American Standards Association (ASA), organized Sectional Committee B16 to unify and further develop national standards for pipe flanges and fittings (and later, for valves, gaskets, and valve actuators). Cosponsors of the B16 Committee were The American Society of Mechanical Engineers (ASME), the Heating and Piping Contractors National Association [now the Mechanical Contractors Association of America (MCAA)], and the Manufacturers Standardization Society of the Valve and Fittings Industry (MSS). Cosponsors were later designated as cosecretariat organizations.

Standardization of welding fittings was initiated in 1937 by a subgroup (designated Subgroup 6) of Subcommittee 3. After consideration of several drafts, a standard was approved by the Committee, cosponsors, and ASA, and published with the designation ASA B16.9-1940.

Revisions were made in 1950 and 1955 to add sizes up to NPS 24 and to complete coverage of fittings in some sizes. These revisions were approved and published as ASA B16.9-1951 and ASA B16.9-1958. With the subgroup now designated Subcommittee 6 (later Subcommittee F), further revisions were begun to clarify the intent of the standard, to add angularity tolerances, and to include fittings of different types (long radius reducing elbows and crosses) and smaller sizes (NPS $\frac{1}{4}$ and NPS $\frac{1}{2}$). This revision was published as ASA B16.9-1964 after ASA approval.

After reorganization of ASA, first as the United States of America Standards Institute (USASI), then as the American National Standards Institute (ANSI), with the Sectional Committee being redesignated as an American National Standards Committee, another revision increasing the size range to NPS 48 and revising the text for clarity was approved and published as ANSI B16.9-1971.

In 1975, Subcommittee F began a major revision to bring the standard up to date with current practice and usage. Common fractions were expressed as decimals (but without intending higher precision) and metric dimensional equivalents were added. Provisions for step-wise change of radius for NPS $\frac{3}{4}$ long radius elbows and 180-deg returns were introduced. Following Standards Committee, cosecretariat, and ANSI approval, the revision was published as ANSI B16.9-1978. It was updated by a corrective addendum, B16.9a-1981, issued in February 1982.

In 1982, American National Standards Committee B16 was reorganized as an ASME Committee operating under procedures accredited by ANSI. In ASME/ANSI B16.9-1986, the text was revised and inch dimensions were established as the standard.

In 1991, the Subcommittee reviewed the document and made a number of revisions that were included in ASME B16.9-1993. Dimensions for short pattern lap joints were also added.

In ASME B16.9-2001, short radius elbows and returns were added, which included all dimensions and tolerances of ASME B16.28-1994. Metric units were provided as an independent but parallel alternative standard to U.S. Customary units, and a Quality System Program appendix was added.

In 2003, the Subcommittee reviewed the document and made a number of revisions. The scope of the standard was changed to permit fabricated lap joint stub ends employing circumferential or intersection welds.

In 2006, the Subcommittee reviewed the document and made a number of additions and revisions. Segmental elbow requirements were added as were 3D elbow dimensions. Reference documents were updated.

In 2012, the Subcommittee reviewed the document and made numerous revisions to the design proof test in section 9 and updated the references in Mandatory Appendix II.

This Standard was approved as an American National Standard on November 16, 2012.

ASME B16 COMMITTEE

Standardization of Valves, Flanges, Fittings, and Gaskets

(The following is the roster of the Committee at the time of approval of this Standard.)

STANDARDS COMMITTEE OFFICERS

W. B. Bedesem, *Chair*
G. A. Jolly, *Vice Chair*
C. E. O'Brien, *Secretary*

STANDARDS COMMITTEE PERSONNEL

A. Appleton , Alloy Stainless Products Co., Inc.	G. A. Jolly , Vogt Valves/Flowserve Corp.
R. W. Barnes , Anric Enterprises, Inc.	M. Katcher , Haynes International
W. B. Bedesem , Consultant	W. N. McLean , B&L Engineering
R. M. Bojarczuk , ExxonMobil Research & Engineering Co.	T. A. McMahon , Emerson Process Management
D. F. Buccicone , Elkhart Products Corp.	M. L. Nayyar , Consultant
A. M. Cheta , Shell Exploration and Production Co.	C. E. O'Brien , The American Society of Mechanical Engineers
M. A. Clark , NIBCO, Inc.	W. H. Patrick , The Dow Chemical Co.
G. A. Cuccio , Capitol Manufacturing Co.	R. A. Schmidt , Canadoil
C. E. Davila , Crane Energy	H. R. Sonderegger , Fluoroseal, Inc.
D. R. Frikken , Becht Engineering Co.	W. M. Stephan , Flexitallic LP
R. P. Griffiths , U.S. Coast Guard	F. R. Volgstadt , Volgstadt & Associates, Inc.
	D. A. Williams , Southern Co. Generation

SUBCOMMITTEE F — STEEL THREADED AND WELDING FITTINGS

G. Cuccio , <i>Chair</i> , Capitol Manufacturing Co.	D. R. Frikken , Becht Engineering Co.
A. Appleton , <i>Vice Chair</i> , Alloy Stainless Products Co., Inc.	D. Hunt, Jr. , Fastenal
F. Huang , <i>Secretary</i> , The American Society of Mechanical Engineers	G. A. Jolly , Vogt Valves/Flowserve Corp.
W. J. Birkholz , Ezeflow USA, Inc.	D. H. Monroe , Consultant
K. W. Doughty , Shaw Alloy Piping Products, Inc.	J. P. Tucker , Flowserve Corp.
J. P. Ellenberger , Retired	G. T. Walden , Wolsley
B. G. Fabian , Pennsylvania Machine Works	M. M. Zaidi , Jacobs Engineering Group, Inc.

CORRESPONDENCE WITH THE B16 COMMITTEE

General. ASME Standards are developed and maintained with the intent to represent the consensus of concerned interests. As such, users of this Standard may interact with the Committee by requesting interpretations, proposing revisions, and attending Committee meetings. Correspondence should be addressed to:

Secretary, B16 Standards Committee
The American Society of Mechanical Engineers
Two Park Avenue
New York, NY 10016-5990

As an alternative, inquiries may be submitted via e-mail to: SecretaryB16@asme.org.

Proposing Revisions. Revisions are made periodically to the Standard to incorporate changes that appear necessary or desirable, as demonstrated by the experience gained from the application of the Standard. Approved revisions will be published periodically.

The Committee welcomes proposals for revisions to this Standard. Such proposals should be as specific as possible, citing the paragraph number(s), the proposed wording, and a detailed description of the reasons for the proposal, including any pertinent documentation.

Proposing a Case. Cases may be issued for the purpose of providing alternative rules when justified, to permit early implementation of an approved revision when the need is urgent, or to provide rules not covered by existing provisions. Cases are effective immediately upon ASME approval and shall be posted on the ASME Committee Web page.

Requests for Cases shall provide a Statement of Need and Background Information. The request should identify the Standard, the paragraph, figure or table number(s), and be written as a Question and Reply in the same format as existing Cases. Requests for Cases should also indicate the applicable edition(s) of the Standard to which the proposed Case applies.

Interpretations. Upon request, the B16 Committee will render an interpretation of any requirement of the Standard. Interpretations can only be rendered in response to a written request sent to the Secretary of the B16 Standards Committee.

The request for interpretation should be clear and unambiguous. It is further recommended that the inquirer submit his/her request in the following format:

Subject: Cite the applicable paragraph number(s) and the topic of the inquiry.
Edition: Cite the applicable edition of the Standard for which the interpretation is being requested.
Question: Phrase the question as a request for an interpretation of a specific requirement suitable for general understanding and use, not as a request for an approval of a proprietary design or situation. The inquirer may also include any plans or drawings, that are necessary to explain the question; however, they should not contain proprietary names or information.

Requests that are not in this format may be rewritten in the appropriate format by the Committee prior to being answered, which may inadvertently change the intent of the original request.

ASME procedures provide for reconsideration of any interpretation when or if additional information that might affect an interpretation is available. Further, persons aggrieved by an interpretation may appeal to the cognizant ASME Committee or Subcommittee. ASME does not "approve," "certify," "rate," or "endorse" any item, construction, proprietary device, or activity.

Attending Committee Meetings. The B16 Standards Committee regularly holds meetings that are open to the public. Persons wishing to attend any meeting should contact the Secretary of the B16 Standards Committee.

ASME B16.9-2012 SUMMARY OF CHANGES

Following approval by the B16 Committee and ASME, and after public review, ASME B16.9-2012 was approved by the American National Standards Institute on November 16, 2012.

ASME B16.9-2012 consists of editorial changes, revisions, and corrections identified by a margin note, **(12)**, placed next to the affected area.

<i>Page</i>	<i>Location</i>	<i>Change</i>
3	9.1	First paragraph revised
	9.2.1	First sentence revised
	9.2.2	First paragraph revised
4, 5	9.3	Revised
	9.4.3	Revised
	9.5	Added
	9.6	Added
37	Mandatory Appendix II	Updated

INTENTIONALLY LEFT BLANK

FACTORY-MADE WROUGHT BUTTWELDING FITTINGS

1 SCOPE

1.1 General

This Standard covers overall dimensions, tolerances, ratings, testing, and markings for factory-made wrought butt welding fittings in sizes NPS ½ through NPS 48 (DN 15 through DN 1200).

1.2 Special Fittings

Fittings may be made to special dimensions, sizes, shapes, and tolerances by agreement between the manufacturer and the purchaser.

1.3 Fabricated Fittings

Fabricated laterals and other fittings employing circumferential or intersection welds are considered pipe fabrication and are not within the scope of this Standard.

Fabricated lap joint stub ends are exempt from the above restrictions, provided they meet all the requirements of the applicable ASTM material specification listed in section 5.

1.4 Relevant Units

This Standard states values in both SI (Metric) and U.S. Customary units. These systems of units are to be regarded separately as standard. Within the text, the U.S. Customary units are shown in parentheses or in separate tables that appear in Mandatory Appendix I. The values stated in each system are not exact equivalents; therefore, it is required that each system of units be used independently of the other. Combining values from the two systems constitutes nonconformance with the Standard.

The designation for size is NPS for both metric- and customary-dimensioned fittings. Fitting pressure rating is associated with the connecting wall thickness of pipe of equivalent size and material.

1.5 References

1.5.1 Referenced Standards. Standards and specifications adopted by reference in this Standard are shown in Mandatory Appendix II. It is not considered practical to identify the specific edition of each standard and specification in the individual references. Instead, the specific edition reference is identified in Mandatory Appendix II. A product made in conformance with a prior edition of referenced standards and in all other

respects conforming to this Standard will be considered to be in conformance.

1.5.2 Codes and Regulations. A fitting used under the jurisdiction of the ASME Boiler and Pressure Vessel Code, the ASME Code for Pressure Piping, or a governmental regulation is subject to any limitation of that code or regulation. This includes any maximum temperature limitation or rule governing the use of a material at low temperature.

1.6 Service Conditions

Criteria for selection of fitting types and materials suitable for particular fluid service are not within the scope of this Standard.

1.7 Welding

Installation welding requirements are outside the scope of this Standard.

1.8 Quality Systems

Nonmandatory requirements relating to the fitting manufacturer's Quality System Program are described in Nonmandatory Appendix A.

1.9 Convention

For determining conformance with this Standard, the convention for fixing significant digits where limits (maximum and minimum values) are specified, shall be as defined in ASTM E29. This requires that an observed or calculated value be rounded off to the nearest unit in the last right-hand digit used for expressing the limit. Decimal values and tolerances do not imply a particular method of measurement.

1.10 Pressure Rating Designation

Class followed by a dimensionless number is the designation for pressure-temperature ratings. Standardized designations for flanges per ASME B16.5 referenced in this Standard are Classes 150, 300, 600, 900, 1500, and 2500.

2 PRESSURE RATINGS

2.1 Basis of Ratings

The allowable pressure ratings for fittings designed in accordance with this Standard may be calculated as for straight seamless pipe of equivalent material

(as shown by comparison of composition and mechanical properties in the respective material specifications) in accordance with the rules established in the applicable sections of ASME B31, Code for Pressure Piping. For the calculation, applicable data for the pipe size, wall thickness, and material that are equivalent to that of the fitting shall be used. Pipe size, wall thickness (or schedule number), and material identity on the fittings are in lieu of pressure rating markings.

2.2 Design of Fittings

The design of fittings shall be established by mathematical analyses (e.g., ASME B16.49 for bends) contained in nationally recognized pressure vessel or piping codes, or at the manufacturer's option by proof testing in accordance with section 9 of this Standard. In order to meet design or manufacturing requirements, it is expected that some portion of formed fittings may have to be thicker than the pipe wall with which the fitting is intended to be used. The mathematical analyses, if used, may take into account such thicker sections. Records of mathematical analysis and/or successful proof test data shall be available at the manufacturer's facility for inspection by the purchaser.

3 SIZE

NPS, followed by a dimensionless number, is the designation for nominal fitting size. NPS is related to the reference nominal diameter, DN, used in international standards. The relationship is, typically, as follows:

DN	NPS
15	$\frac{1}{2}$
20	$\frac{3}{4}$
25	1
32	$1\frac{1}{4}$
40	$1\frac{1}{2}$
50	2
65	$2\frac{1}{2}$
80	3
100	4

NOTE: For NPS > 4, the equivalence is DN = 25 × NPS.

4 MARKING

4.1 Standard Marking

Each fitting shall be permanently marked to show the following:

- (a) manufacturer's name or trademark
- (b) material identification, either the ASTM or ASME grade designation

(c) schedule number¹ or nominal wall thickness in mm

(d) size — the nominal pipe size (NPS) identification number related to the end connections shall be used

(e) compliance — see para. 4.4 for standard and special fitting marking

A manufacturer may supplement these mandatory markings with others, including a DN size designation, but confusion with the required marking shall be avoided.

4.2 Exceptions

Where the size of the fitting does not permit complete marking, the identification marks may be omitted in reverse of the order presented in para. 4.1.

4.3 Depth of Stamping

Where steel stamps are used, care shall be taken so that the marking is not deep enough or sharp enough to cause cracks or to reduce the wall thickness of the fitting below the minimum allowed.

4.4 Compliance

4.4.1 Standard Fittings. That the fitting was manufactured in conformance with this Standard, including all dimensional requirements, is certified by a prefix "WP" in the material grade designation marking.

4.4.2 Special Fittings. That the fitting was manufactured in conformance with this Standard, except that dimensional requirements are as agreed between the purchaser and the manufacturer, is certified by a supplementary suffix to the material grade designation marking as follows:

(a) "S58" of ASTM A960 applies for fittings in accordance with ASTM A234, A403, and A420.

(b) "S8" applies for fittings in accordance with ASTM A815.

(c) "SPLD" applies for fittings in accordance with ASTM B361, B363, and B366.

5 MATERIAL

Wrought fittings covered by this Standard shall be in accordance with ASTM A234, A403, A420, A815, B361, B363, B366, or the corresponding standard listed in Section II of the ASME Boiler and Pressure Vessel Code. The term *wrought* denotes fittings made of pipe, tubing, plate, or forgings. Fittings made from block forgings may only be supplied subject to agreement between the manufacturer and purchaser. Such fittings need not meet the requirements of section 7.

¹ Schedule number is a dimensionless number that is widely used as a convenient designation for use in ordering pipe and fittings. It is normally associated with a group of standardized pipe wall thickness. Refer to ASME B36.10M and ASME B36.19M for complete details on pipe schedule numbers.

6 FITTING DIMENSIONS

6.1 General

This Standard provides for a fixed position for the welding ends with reference to either the centerline of the fittings or the overall dimensions. Dimensional requirements for these fittings are to be found in Tables 1 through 11 and Tables I-1 through I-11 of Mandatory Appendix I.

6.2 Special Dimensions

6.2.1 Fatigue Loading. For applications where fatigue loading is a concern, required minimum dimensions shall be furnished by the purchaser.

6.2.2 Bore Diameter. Bore diameters away from the ends are not specified. If special flow path requirements are needed, the bore dimensions shall be specified by the purchaser.

6.2.3 Stub Ends. Service conditions and joint construction often dictate stub end length requirements. Therefore, the purchaser must specify long or short pattern fitting when ordering. [See General Note (c) in Tables 9 and I-9.]

6.2.4 Segmental Elbows. Factory-made segments of short radius, long radius, and 3D radius elbows may be made to meet customer angle requirements. With the exception of the B dimension, factory-made segments of elbows shall meet all other requirements of this Standard. The B dimension for segmented elbows can be calculated as follows:

For segments of 90-deg elbows

$$B_s = A \times \tan(\theta/2)$$

where

A = dimension A for appropriate 90-deg elbow being segmented from

(a) Table 1/Table I-1 for long radius elbow, mm (in.)

(b) Table 4/Table I-4 for short radius elbow, mm (in.)

(c) Table 6/Table I-6 for 3D elbow, mm (in.)

B_s = center-to-end dimension for segmented elbow

θ = angle of segmented elbow — 30 deg, 60 deg, 75 deg, etc.

When special elbows are intended for field segmenting, the outside or inside diameter tolerance shall be furnished throughout the fitting by agreement between the manufacturer and the purchaser. Any mismatch on the outside or inside diameter needs to be corrected in the field by grinding, back-welding, or bridging of weld to meet the applicable piping code requirements. Although the elbow intended for field-segmenting must meet the requirements of this

Standard, once the field-segmented elbow is cut, it is not a B16.9 product.

7 SURFACE CONTOURS

Where adjacent openings in fittings are not in parallel planes, they shall be joined by a circular arc or radius on the external surfaces. The arc or radius may be terminated in tangents. Except as provided for block forgings (see section 5), the projected profile of external surfaces of fittings shall not have sharp intersections (corners) and/or collapsed arcs.

8 END PREPARATION

Unless otherwise specified, the details of the welding end preparation shall be in accordance with Table 12. Transitions from the welding bevel to the outside surface of the fitting and from the root face to the inside surface of the fitting lying within the maximum envelope shown in Fig. 1 are at the manufacturer's option, except as covered in Note (5) of Fig. 1 or unless otherwise specifically ordered.

9 DESIGN PROOF TEST

9.1 Required Tests

(12)

Proof tests shall be made as set forth in this Standard when the manufacturer chooses proof testing to qualify the fitting design. The proof test shall be based on the computed burst pressure of the fitting and its connecting piping as defined in para. 9.3. A factory-made segmented elbow (see para. 6.2.4) that has a proof test on a geometrically similar 90-deg elbow need not be tested separately.

Lap joint stub ends are exempt from proof testing because they are used in a flange assembly, which will have different ratings depending on service application.

9.2 Test Assembly

9.2.1 Representative Components. Fittings that have the same basic design configuration and method of manufacture shall be selected from production for testing and shall be identified as to material, grade, and lot, including heat treatment. They shall be inspected for dimensional compliance to this Standard. (12)

9.2.2 Other Components. Straight seamless or welded pipe whose calculated bursting strength is at least as great as the proof test pressure as calculated in para. 9.3 shall be welded to each end of the fitting to be tested. Pipe sections may have the nominal wall greater than the thickness indicated by the fitting markings. That greater thickness shall not exceed 1.5 times the fitting markings wall. Any internal misalignment greater than 1.5 mm (0.06 in.) shall be reduced by taper boring at a slope not over 1:3. Any other unequal wall (12)

welding preparation shall be in accordance with ASME B16.25. Length of pipe sections for closures shall be as follows:

(a) Minimum length of pipe shall be one pipe O.D. for NPS 14 (DN 350) and smaller.

(b) Minimum length of pipe shall be one-half pipe O.D. for NPS greater than 14 (DN 350).

(12) 9.3 Test Procedure

The test fluid shall be water or other liquid. Hydrostatic pressure shall be applied to the assembly.

At least three specimen tests for each fitting, joint size, or configuration are recommended. The testing factor, *f*, based on the number of specimen tests performed in the table below is used in the computed test equations.

Number of Tests	Testing Factor, <i>f</i>
1	1.10
2	1.05
3	1.00

NOTE: Tests of geometrically identical fittings that meet the requirements specified in para. 9.4 may be combined to establish the test factor applied to a set of fittings.

The test shall be taken to rupture or held at or above the computed minimum proof pressure for a period of at least 3 min. The test is successful if for each of the tests, the fitting withstands without rupture a proof test pressure at least equal to the computed minimum.

$$P = \frac{2St}{D}f$$

where

D = specified outside diameter of pipe

f = testing factor from in-text table listed in para. 9.3

P = computed minimum proof test pressure for fitting

S = actual tensile strength of the test fitting, determined on a specimen representative of the test fitting, which shall meet the tensile strength requirements of the applicable material of section 5

t = nominal pipe wall thickness of the pipe that the fitting marking identifies

NOTE: Any dimensionally consistent system of units may be used.

9.4 Applicability of Test Results

It is not necessary to conduct an individual test of fittings with all combinations of sizes, wall thicknesses, and materials. A successful proof test on one representative fitting may represent others to the extent described in paras. 9.4.1, 9.4.2, and 9.4.3.

9.4.1 Size Range. One test fitting may be used to qualify similarly proportioned fittings with a size range from one-half to twice that for the tested fitting. The test of a nonreducing fitting qualifies reducing fittings of the same pattern. The test of a reducing fitting qualifies reductions to smaller sizes.

9.4.2 Thickness Range. One test fitting may be used to qualify similarly proportioned fittings with *t/D* ranges from one-half to three times that for the tested fitting.

9.4.3 Material Grades. The pressure retaining capacity of a geometrically identical fitting made of various grades of steel as listed in section 5 will be directly proportional to the tensile properties of the materials, provided the yield-to-tensile ratio as specified in the applicable specification of that material is 0.84 or less. Therefore, it is necessary to test only a single material in a representative fitting to prove the design of the fitting. (12)

9.5 Maintenance of Results (12)

The manufacturer shall have a quality control (QC) program that verifies the manufacturing process used and ensures that the resulting geometry of the fittings or joints manufactured reasonably conforms to the geometries tested. The QC program shall control the manufacturing drawings and maintain the QC records showing conformance to these drawings.

Tests made in accordance with and at the time of previous editions of this test are not intended to be nullified by the changes made in this edition's test procedure and requirement.

Whenever a significant change is made in the geometry or method of manufacture, the manufacturer shall either retest the new production or show by analysis that the change would not affect the results of prior tests.

9.6 Proof Test Report (12)

A report of the testing for each joint configuration shall be prepared and shall include

- (a) description of the test, including the number of tests and *f* factor used to establish the target proof test
- (b) instrumentation and methods of calibrations used
- (c) material test reports for the assembly's materials
- (d) actual final pressures for each test
- (e) length of time from test initiation to the time of burst, or the hold time at or above the computed target pressure
- (f) calculations performed
- (g) location of rupture, if any, including a sketch
- (h) certification by a registered Professional Engineer experienced in pressure component design or a licensed Authorized Inspector

The test report shall be made available at the manufacturer's facility for inspection by the purchaser or regulatory authority.

10 PRODUCTION TESTS

Hydrostatic testing of wrought fittings is not required by this Standard. All fittings shall be capable of withstanding, without leakage or impairment of serviceability, a hydrostatic test pressure required by the applicable piping code for seamless pipe of material equivalent to

the fitting material, and of the size and wall thickness the fitting marking identifies.

11 TOLERANCES

Tolerances for fittings are shown in Tables 13 and I-12, and apply to the nominal dimensions given in Tables 1 through 11 and Tables I-1 through I-11. Where given in the tables, the minimum and maximum dimensions are based on these tolerances. The listings with decimals do not imply precision measurement, such as use of vernier, micrometer, electronic readout equipment, etc.

ASME B16.9-2012

Fig. 1 Maximum Envelope for Welding End Transitions

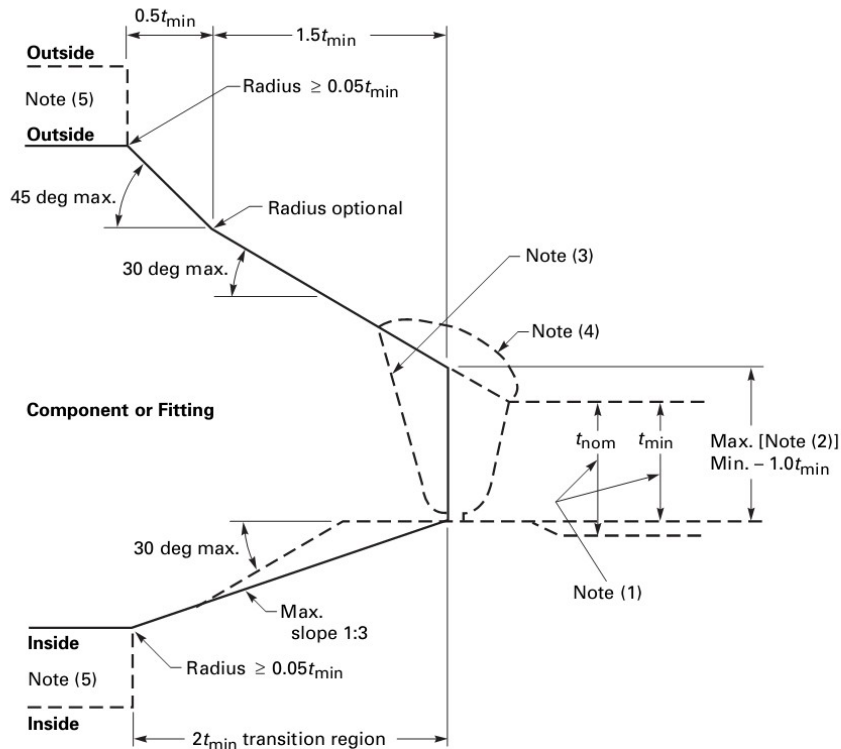

NOTES:

- (1) The value of t_{min} is whichever of the following is applicable:
 - (a) the minimum ordered wall thickness of the pipe, to include pipe that is purchased to a nominal wall thickness with an undertolerance other than 12.5%
 - (b) 0.875 times the nominal wall thickness of pipe ordered to a pipe schedule wall thickness that has an undertolerance of 12.5%
- (2) The maximum thickness at the end of the component is as follows:
 - (a) the greater of [$t_{min} + 4 \text{ mm (0.16 in.)}$] or $1.15t_{min}$ when ordered on a minimum wall basis
 - (b) the greater of [$t_{min} + 4 \text{ mm (0.16 in.)}$] or $1.10t_{nom}$ when ordered on a nominal wall basis
- (3) Weld bevel shown is for illustration only.
- (4) The weld reinforcement permitted by applicable code may lie outside the maximum envelope.
- (5) Where transitions using maximum slope do not intersect the inside or outside surfaces within the transition region, as shown by phantom outline, maximum slopes shall be used. Alternatively, radii lying within the envelope may be used.

ASME B16.9-2012

Table 1 Dimensions of Long Radius Elbows

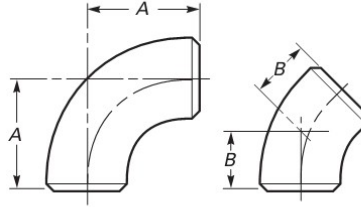

Nominal Pipe Size (NPS)	Outside Diameter at Bevel	Center-to-End	
		90-deg Elbows, A	45-deg Elbows, B
1/2	21.3	38	16
3/4	26.7	38	19
1	33.4	38	22
1 1/4	42.2	48	25
1 1/2	48.3	57	29
2	60.3	76	35
2 1/2	73.0	95	44
3	88.9	114	51
3 1/2	101.6	133	57
4	114.3	152	64
5	141.3	190	79
6	168.3	229	95
8	219.1	305	127
10	273.0	381	159
12	323.8	457	190
14	355.6	533	222
16	406.4	610	254
18	457.0	686	286
20	508.0	762	318
22	559.0	838	343
24	610.0	914	381
26	660.0	991	406
28	711.0	1 067	438
30	762.0	1 143	470
32	813.0	1 219	502
34	864.0	1 295	533
36	914.0	1 372	565
38	965.0	1 448	600
40	1 016.0	1 524	632
42	1 067.0	1 600	660
44	1 118.0	1 676	695
46	1 168.0	1 753	727
48	1 219.0	1 829	759

GENERAL NOTE: All dimensions are in millimeters.

ASME B16.9-2012

Table 2 Dimensions of Long Radius Reducing Elbows

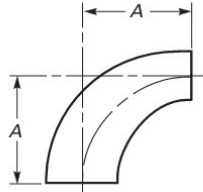

Nominal Pipe Size (NPS)	Outside Diameter at Bevel		Center-to-End, A	Nominal Pipe Size (NPS)	Outside Diameter at Bevel		Center-to-End, A
	Large End	Small End			Large End	Small End	
2 × 1½	60.3	48.3	76	10 × 8	273.0	219.1	381
2 × 1¼	60.3	42.2	76	10 × 6	273.0	168.3	381
2 × 1	60.3	33.4	76	10 × 5	273.0	141.3	381
2½ × 2	73.0	60.3	95	12 × 10	323.8	273.0	457
2½ × 1½	73.0	48.3	95	12 × 8	323.8	219.1	457
2½ × 1¼	73.0	42.2	95	12 × 6	323.8	168.3	457
3 × 2½	88.9	73.0	114	14 × 12	355.6	323.8	533
3 × 2	88.9	60.3	114	14 × 10	355.6	273.0	533
3 × 1½	88.9	48.3	114	14 × 8	355.6	219.1	533
3½ × 3	101.6	88.9	133	16 × 14	406.4	355.6	610
3½ × 2½	101.6	73.0	133	16 × 12	406.4	323.8	610
3½ × 2	101.6	60.3	133	16 × 10	406.4	273.0	610
4 × 3½	114.3	101.6	152	18 × 16	457.0	406.4	686
4 × 3	114.3	88.9	152	18 × 14	457.0	355.6	686
4 × 2½	114.3	73.0	152	18 × 12	457.0	323.8	686
4 × 2	114.3	60.3	152	18 × 10	457.0	273.0	686
5 × 4	141.3	114.3	190	20 × 18	508.0	457.0	762
5 × 3½	141.3	101.6	190	20 × 16	508.0	406.4	762
5 × 3	141.3	88.9	190	20 × 14	508.0	355.6	762
5 × 2½	141.3	73.0	190	20 × 12	508.0	323.8	762
				20 × 10	508.0	273.0	762
6 × 5	168.3	141.3	229	24 × 22	610.0	559.0	914
6 × 4	168.3	114.3	229	24 × 20	610.0	508.0	914
6 × 3½	168.3	101.6	229	24 × 18	610.0	457.0	914
6 × 3	168.3	88.9	229	24 × 16	610.0	406.4	914
8 × 6	219.1	168.3	305	24 × 14	610.0	355.6	914
8 × 5	219.1	141.3	305	24 × 12	610.0	323.8	914
8 × 4	219.1	114.3	305

GENERAL NOTE: All dimensions are in millimeters.

ASME B16.9-2012

Table 3 Dimensions of Long Radius Returns

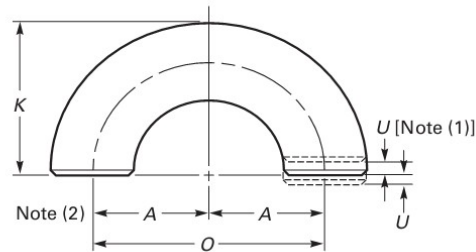

Nominal Pipe Size (NPS)	Outside Diameter at Bevel	Center-to-Center, <i>O</i>	Back-to-Face, <i>K</i>
1/2	21.3	76	48
3/4	26.7	76	51
1	33.4	76	56
1 1/4	42.2	95	70
1 1/2	48.3	114	83
2	60.3	152	106
2 1/2	73.0	190	132
3	88.9	229	159
3 1/2	101.6	267	184
4	114.3	305	210
5	141.3	381	262
6	168.3	457	313
8	219.1	610	414
10	273.0	762	518
12	323.8	914	619
14	355.6	1 067	711
16	406.4	1 219	813
18	457.0	1 372	914
20	508.0	1 524	1 016
22	559.0	1 676	1 118
24	610.0	1 829	1 219

GENERAL NOTE: All dimensions are in millimeters.

NOTES:

(1) See Table 13 for tolerance for alignment of ends *U*.

(2) Dimension *A* is equal to one-half of dimension *O*.

ASME B16.9-2012

Table 4 Dimensions of Short Radius Elbows

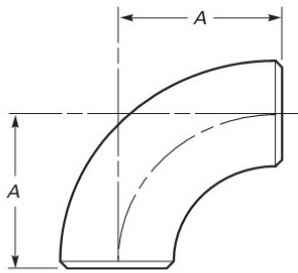

Nominal Pipe Size (NPS)	Outside Diameter at Bevel	Center-to-End, A
1	33.4	25
1¼	42.2	32
1½	48.3	38
2	60.3	51
2½	73.0	64
3	88.9	76
3½	101.6	89
4	114.3	102
5	141.3	127
6	168.3	152
8	219.1	203
10	273.0	254
12	323.8	305
14	355.6	356
16	406.4	406
18	457.0	457
20	508.0	508
22	559.0	559
24	610.0	610

GENERAL NOTE: All dimensions are in millimeters.

Table 5 Dimensions of Short Radius 180-deg Returns

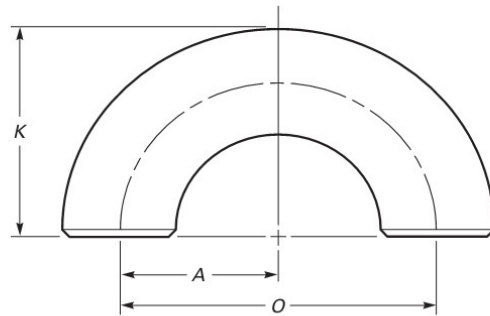

Nominal Pipe Size (NPS)	Outside Diameter at Bevel	Center-to-Center, O	Back-to-Face, K
1	33.4	51	41
1¼	42.2	64	52
1½	48.3	76	62
2	60.3	102	81
2½	73.0	127	100
3	88.9	152	121
3½	101.6	178	140
4	114.3	203	159
5	141.3	254	197
6	168.3	305	237
8	219.1	406	313
10	273.0	508	391
12	323.8	610	467
14	355.6	711	533
16	406.4	813	610
18	457.0	914	686
20	508.0	1 016	762
22	559.0	1 118	838
24	610.0	1 219	914

GENERAL NOTES:

- (a) All dimensions are in millimeters.
- (b) Dimension A is equal to one-half of dimension O.

ASME B16.9-2012

Table 6 Dimensions of 3D Elbows

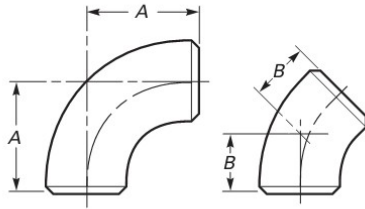

Nominal Pipe Size (NPS)	Outside Diameter at Bevel	Center-to-End	
		90-deg Elbows, A	45-deg Elbows, B
3/4	26.7	57	24
1	33.4	76	31
1 1/4	42.2	95	39
1 1/2	48.3	114	47
2	60.3	152	63
2 1/2	73.0	190	79
3	88.9	229	95
3 1/2	101.6	267	111
4	114.3	305	127
5	141.3	381	157
6	168.3	457	189
8	219.1	610	252
10	273.0	762	316
12	323.8	914	378
14	355.6	1 067	441
16	406.4	1 219	505
18	457.0	1 372	568
20	508.0	1 524	632
22	559.0	1 676	694
24	610.0	1 829	757
26	660.0	1 981	821
28	711.0	2 134	883
30	762.0	2 286	964
32	813.0	2 438	1 010
34	864.0	2 591	1 073
36	914.0	2 743	1 135
38	965.0	2 896	1 200
40	1 016.0	3 048	1 264
42	1 067.0	3 200	1 326
44	1 118.0	3 353	1 389
46	1 168.0	3 505	1 453
48	1 219.0	3 658	1 516

GENERAL NOTE: All dimensions are in millimeters.

Table 7 Dimensions of Straight Tees and Crosses

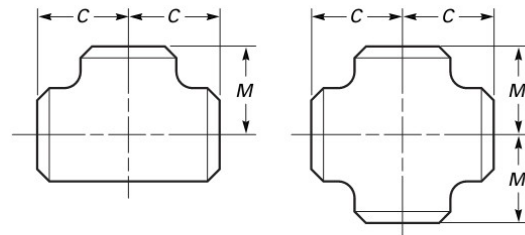

Nominal Pipe Size (NPS)	Outside Diameter at Bevel	Center-to-End	
		Run, C	Outlet, M [Notes (1) and (2)]
1/2	21.3	25	25
3/4	26.7	29	29
1	33.4	38	38
1 1/4	42.2	48	48
1 1/2	48.3	57	57
2	60.3	64	64
2 1/2	73.0	76	76
3	88.9	86	86
3 1/2	101.6	95	95
4	114.3	105	105
5	141.3	124	124
6	168.3	143	143
8	219.1	178	178
10	273.0	216	216
12	323.8	254	254
14	355.6	279	279
16	406.4	305	305
18	457.0	343	343
20	508.0	381	381
22	559.0	419	419
24	610.0	432	432
26	660.0	495	495
28	711.0	521	521
30	762.0	559	559
32	813.0	597	597
34	864.0	635	635
36	914.0	673	673
38	965.0	711	711
40	1 016.0	749	749
42	1 067.0	762	711
44	1 118.0	813	762
46	1 168.0	851	800
48	1 219.0	889	838

GENERAL NOTE: All dimensions are in millimeters.

NOTES:

- (1) Outlet dimension M for NPS 26 and larger is recommended but not required.
- (2) Dimensions applicable to crosses NPS 24 and smaller.

ASME B16.9-2012

Table 8 Dimensions of Reducing Outlet Tees and Reducing Outlet Crosses

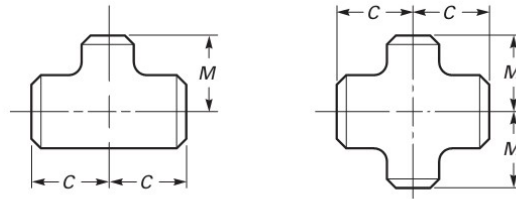

Nominal Pipe Size (NPS)	Outside Diameter at Bevel		Center-to-End		Nominal Pipe Size (NPS)	Outside Diameter at Bevel		Center-to-End	
	Run	Outlet	Run, C	Outlet, M [Note (1)]		Run	Outlet	Run, C	Outlet, M [Note (1)]
1/2 x 1/2 x 3/8	21.3	17.3	25	25	4 x 4 x 3 1/2	114.3	101.6	105	102
1/2 x 1/2 x 1/4	21.3	13.7	25	25	4 x 4 x 3	114.3	88.9	105	98
3/4 x 3/4 x 1/2	26.7	21.3	29	29	4 x 4 x 2 1/2	114.3	73.0	105	95
3/4 x 3/4 x 3/8	26.7	17.3	29	29	4 x 4 x 2	114.3	60.3	105	89
1 x 1 x 3/4	33.4	26.7	38	38	4 x 4 x 1 1/2	114.3	48.3	105	86
1 x 1 x 1/2	33.4	21.3	38	38					
					5 x 5 x 4	141.3	114.3	124	117
1 1/4 x 1 1/4 x 1	42.2	33.4	48	48	5 x 5 x 3 1/2	141.3	101.6	124	114
1 1/4 x 1 1/4 x 3/4	42.2	26.7	48	48	5 x 5 x 3	141.3	88.9	124	111
1 1/4 x 1 1/4 x 1/2	42.2	21.3	48	48	5 x 5 x 2 1/2	141.3	73.0	124	108
					5 x 5 x 2	141.3	60.3	124	105
1 1/2 x 1 1/2 x 1 1/4	48.3	42.2	57	57	6 x 6 x 5	168.3	141.3	143	137
1 1/2 x 1 1/2 x 1	48.3	33.4	57	57	6 x 6 x 4	168.3	114.3	143	130
1 1/2 x 1 1/2 x 3/4	48.3	26.7	57	57	6 x 6 x 3 1/2	168.3	101.6	143	127
1 1/2 x 1 1/2 x 1/2	48.3	21.3	57	57	6 x 6 x 3	168.3	88.9	143	124
					6 x 6 x 2 1/2	168.3	73.0	143	121
2 x 2 x 1 1/2	60.3	48.3	64	60	8 x 8 x 6	219.1	168.3	178	168
2 x 2 x 1 1/4	60.3	42.2	64	57	8 x 8 x 5	219.1	141.3	178	162
2 x 2 x 1	60.3	33.4	64	51	8 x 8 x 4	219.1	114.3	178	156
2 x 2 x 3/4	60.3	26.7	64	44	8 x 8 x 3 1/2	219.1	101.6	178	152
2 1/2 x 2 1/2 x 2	73.0	60.3	76	70	10 x 10 x 8	273.0	219.1	216	203
2 1/2 x 2 1/2 x 1 1/2	73.0	48.3	76	67	10 x 10 x 6	273.0	168.3	216	194
2 1/2 x 2 1/2 x 1 1/4	73.0	42.2	76	64	10 x 10 x 5	273.0	141.3	216	191
2 1/2 x 2 1/2 x 1	73.0	33.4	76	57	10 x 10 x 4	273.0	114.3	216	184
3 x 3 x 2 1/2	88.9	73.0	86	83	12 x 12 x 10	323.8	273.0	254	241
3 x 3 x 2	88.9	60.3	86	76	12 x 12 x 8	323.8	219.1	254	229
3 x 3 x 1 1/2	88.9	48.3	86	73	12 x 12 x 6	323.8	168.3	254	219
3 x 3 x 1 1/4	88.9	42.2	86	70	12 x 12 x 5	323.8	141.3	254	216
3 1/2 x 3 1/2 x 3	101.6	88.9	95	92	14 x 14 x 12	355.6	323.8	279	270
3 1/2 x 3 1/2 x 2 1/2	101.6	73.0	95	89	14 x 14 x 10	355.6	273.0	279	257
3 1/2 x 3 1/2 x 2	101.6	60.3	95	83	14 x 14 x 8	355.6	219.1	279	248
3 1/2 x 3 1/2 x 1 1/2	101.6	48.3	95	79	14 x 14 x 6	355.6	168.3	279	238

ASME B16.9-2012

Table 8 Dimensions of Reducing Outlet Tees and Reducing Outlet Crosses (Cont'd)

Nominal Pipe Size (NPS)	Outside Diameter at Bevel		Center-to-End		Nominal Pipe Size (NPS)	Outside Diameter at Bevel		Center-to-End	
	Run	Outlet	Run, C	Outlet, M [Note (1)]		Run	Outlet	Run, C	Outlet, M [Note (1)]
16 × 16 × 14	406.4	355.6	305	305	28 × 28 × 26	711	660.0	521	521
16 × 16 × 12	406.4	323.8	305	295	28 × 28 × 24	711	610.0	521	508
16 × 16 × 10	406.4	273.0	305	283	28 × 28 × 22	711	559.0	521	495
16 × 16 × 8	406.4	219.1	305	273	28 × 28 × 20	711	508.0	521	483
16 × 16 × 6	406.4	168.3	305	264					
					28 × 28 × 18	711	457.0	521	470
18 × 18 × 16	457.0	406.4	343	330	28 × 28 × 16	711	406.4	521	457
18 × 18 × 14	457.0	355.6	343	330	28 × 28 × 14	711	355.6	521	457
18 × 18 × 12	457.0	323.8	343	321	28 × 28 × 12	711	323.8	521	448
18 × 18 × 10	457.0	273.0	343	308					
18 × 18 × 8	457.0	219.1	343	298	30 × 30 × 28	762	711.0	559	546
					30 × 30 × 26	762	660.0	559	546
20 × 20 × 18	508.0	457.0	381	368	30 × 30 × 24	762	610.0	559	533
20 × 20 × 16	508.0	406.4	381	356	30 × 30 × 22	762	559.0	559	521
20 × 20 × 14	508.0	355.6	381	356	30 × 30 × 20	762	508.0	559	508
20 × 20 × 12	508.0	323.8	381	346					
20 × 20 × 10	508.0	273.0	381	333	30 × 30 × 18	762	457.0	559	495
20 × 20 × 8	508.0	219.1	381	324	30 × 30 × 16	762	406.4	559	483
					30 × 30 × 14	762	355.6	559	483
22 × 22 × 20	559.0	508.0	419	406	30 × 30 × 12	762	323.8	559	473
22 × 22 × 18	559.0	457.0	419	394	30 × 30 × 10	762	273.0	559	460
22 × 22 × 16	559.0	406.4	419	381					
22 × 22 × 14	559.0	355.6	419	381	32 × 32 × 30	813	762.0	597	584
22 × 22 × 12	559.0	323.8	419	371	32 × 32 × 28	813	711.0	597	572
22 × 22 × 10	559.0	273.0	419	359	32 × 32 × 26	813	660.0	597	572
					32 × 32 × 24	813	610.0	597	559
24 × 24 × 22	610.0	559.0	432	432					
24 × 24 × 20	610.0	508.0	432	432	32 × 32 × 22	813	559.0	597	546
24 × 24 × 18	610.0	457.0	432	419	32 × 32 × 20	813	508.0	597	533
					32 × 32 × 18	813	457.0	597	521
24 × 24 × 16	610.0	406.4	432	406	32 × 32 × 16	813	406.4	597	508
24 × 24 × 14	610.0	355.6	432	406	32 × 32 × 14	813	355.6	597	508
24 × 24 × 12	610.0	323.8	432	397					
24 × 24 × 10	610.0	273.0	432	384	34 × 34 × 32	864	813.0	635	622
					34 × 34 × 30	864	762.0	635	610
26 × 26 × 24	660.0	610.0	495	483	34 × 34 × 28	864	711.0	635	597
26 × 26 × 22	660.0	559.0	495	470	34 × 34 × 26	864	660.0	635	597
26 × 26 × 20	660.0	508.0	495	457					
					34 × 34 × 24	864	610.0	635	584
26 × 26 × 18	660.0	457.0	495	444	34 × 34 × 22	864	559.0	635	572
26 × 26 × 16	660.0	406.4	495	432	34 × 34 × 20	864	508.0	635	559
26 × 26 × 14	660.0	355.6	495	432	34 × 34 × 18	864	457.0	635	546
26 × 26 × 12	660.0	323.8	495	422	34 × 34 × 16	864	406.4	635	533

ASME B16.9-2012

Table 8 Dimensions of Reducing Outlet Tees and Reducing Outlet Crosses (Cont'd)

Nominal Pipe Size (NPS)	Outside Diameter at Bevel		Center-to-End		Nominal Pipe Size (NPS)	Outside Diameter at Bevel		Center-to-End	
	Run	Outlet	Run, C	Outlet, M [Note (1)]		Run	Outlet	Run, C	Outlet, M [Note (1)]
36 × 36 × 34	914	864.0	673	660	42 × 42 × 24	1 067	610.0	762	660
36 × 36 × 32	914	813.0	673	648	42 × 42 × 22	1 067	559.0	762	660
36 × 36 × 30	914	762.0	673	635	42 × 42 × 20	1 067	508.0	762	660
36 × 36 × 28	914	711.0	673	622	42 × 42 × 18	1 067	457.0	762	648
36 × 36 × 26	914	660.0	673	622	42 × 42 × 16	1 067	406.4	762	635
36 × 36 × 24	914	610.0	673	610	44 × 44 × 42	1 118	1 067.0	813	762
36 × 36 × 22	914	559.0	673	597	44 × 44 × 40	1 118	1 016.0	813	749
36 × 36 × 20	914	508.0	673	584	44 × 44 × 38	1 118	965.0	813	737
36 × 36 × 18	914	457.0	673	572	44 × 44 × 36	1 118	914.0	813	724
36 × 36 × 16	914	406.4	673	559	44 × 44 × 34	1 118	864.0	813	724
					44 × 44 × 32	1 118	813.0	813	711
38 × 38 × 36	965	914.0	711	711	44 × 44 × 30	1 118	762.0	813	711
38 × 38 × 34	965	864.0	711	698	44 × 44 × 28	1 118	711.0	813	698
38 × 38 × 32	965	813.0	711	686	44 × 44 × 26	1 118	660.0	813	698
38 × 38 × 30	965	762.0	711	673	44 × 44 × 24	1 118	610.0	813	698
38 × 38 × 28	965	711.0	711	648	44 × 44 × 22	1 118	559.0	813	686
					44 × 44 × 20	1 118	508.0	813	686
38 × 38 × 26	965	660.0	711	648	46 × 46 × 44	1 168	1 118.0	851	800
38 × 38 × 24	965	610.0	711	635	46 × 46 × 42	1 168	1 067.0	851	787
38 × 38 × 22	965	559.0	711	622	46 × 46 × 40	1 168	1 016.0	851	775
38 × 38 × 20	965	508.0	711	610	46 × 46 × 38	1 168	965.0	851	762
38 × 38 × 18	965	457.0	711	597	46 × 46 × 36	1 168	914.0	851	762
					46 × 46 × 34	1 168	864.0	851	749
40 × 40 × 38	1 016	965.0	749	749	46 × 46 × 32	1 168	813.0	851	749
40 × 40 × 36	1 016	914.0	749	737	46 × 46 × 30	1 168	762.0	851	737
40 × 40 × 34	1 016	864.0	749	724	46 × 46 × 28	1 168	711.0	851	737
40 × 40 × 32	1 016	813.0	749	711	46 × 46 × 26	1 168	660.0	851	737
40 × 40 × 30	1 016	762.0	749	698	46 × 46 × 24	1 168	610.0	851	724
					46 × 46 × 22	1 168	559.0	851	724
40 × 40 × 28	1 016	711.0	749	673	48 × 48 × 46	1 219	1 168.0	889	838
40 × 40 × 26	1 016	660.0	749	673	48 × 48 × 44	1 219	1 118.0	889	838
40 × 40 × 24	1 016	610.0	749	660	48 × 48 × 42	1 219	1 067.0	889	813
40 × 40 × 22	1 016	559.0	749	648	48 × 48 × 40	1 219	1 016.0	889	813
40 × 40 × 20	1 016	508.0	749	635	48 × 48 × 38	1 219	965.0	889	813
40 × 40 × 18	1 016	457.0	749	622	48 × 48 × 36	1 219	914.0	889	787
					48 × 48 × 34	1 219	864.0	889	787
42 × 42 × 40	1 067	1 016.0	762	711	48 × 48 × 32	1 219	813.0	889	787
42 × 42 × 38	1 067	965.0	762	711	48 × 48 × 30	1 219	762.0	889	762
42 × 42 × 36	1 067	914.0	762	711	48 × 48 × 28	1 219	711.0	889	762
42 × 42 × 34	1 067	864.0	762	711	48 × 48 × 26	1 219	660.0	889	762
					48 × 48 × 24	1 219	610.0	889	737
42 × 42 × 32	1 067	813.0	762	711	48 × 48 × 22	1 219	559.0	889	737
42 × 42 × 30	1 067	762.0	762	711					
42 × 42 × 28	1 067	711.0	762	698					
42 × 42 × 26	1 067	660.0	762	698					

GENERAL NOTE: All dimensions are in millimeters.

NOTE:

(1) Outlet dimension M for run sizes NPS 14 and larger is recommended but not required.

ASME B16.9-2012

Table 9 Dimensions of Lap Joint Stub Ends

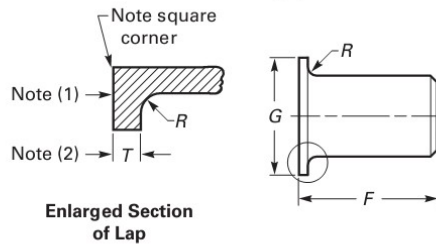

Nominal Pipe Size (NPS)	Outside Diameter of Barrel		Long Pattern Length, F [Notes (3), (4)]	Short Pattern Length, F [Notes (3), (4)]	Radius of Fillet, R [Note (5)]	Diameter of Lap, G [Note (6)]
	Max.	Min.				
1/2	22.8	20.5	76	51	3	35
3/4	28.1	25.9	76	51	3	43
1	35.0	32.6	102	51	3	51
1 1/4	43.6	41.4	102	51	5	64
1 1/2	49.9	47.5	102	51	6	73
2	62.4	59.5	152	64	8	92
2 1/2	75.3	72.2	152	64	8	105
3	91.3	88.1	152	64	10	127
3 1/2	104.0	100.8	152	76	10	140
4	116.7	113.5	152	76	11	157
5	144.3	140.5	203	76	11	186
6	171.3	167.5	203	89	13	216
8	222.1	218.3	203	102	13	270
10	277.2	272.3	254	127	13	324
12	328.0	323.1	254	152	13	381
14	359.9	354.8	305	152	13	413
16	411.0	405.6	305	152	13	470
18	462.0	456.0	305	152	13	533
20	514.0	507.0	305	152	13	584
22	565.0	558.0	305	152	13	641
24	616.0	609.0	305	152	13	692

GENERAL NOTES:

- (a) All dimensions are in millimeters.
- (b) See Table 13 for tolerances.
- (c) Service conditions and joint construction often dictate stub end length requirements. Therefore, the purchaser must specify long or short pattern fitting when ordering.

NOTES:

- (1) Gasket face finish shall be in accordance with ASME B16.5 for raised face flanges.
- (2) The lap thickness, T , shall not be less than nominal pipe wall thickness. See Table 13 for maximum tolerance.
- (3) When short pattern stub ends are used with larger flanges in Classes 300 and 600, with most sizes in Classes 900 and higher, and when long pattern stub ends are used with larger flanges in Classes 1500 and 2500, it may be necessary to increase the length of the stub ends in order to avoid covering the weld with the flange. Such increases in length shall be a matter of agreement between the manufacturer and purchaser.
- (4) When special facings such as tongue and groove, male and female, etc., are employed, additional lap thickness must be provided and such additional thickness shall be in addition to (not included in) the basic length, F .
- (5) These dimensions conform to the radius established for lap joint flanges in ASME B16.5.
- (6) This dimension conforms to standard machined facings shown in ASME B16.5. The back face of the lap shall be machined to conform to the surface on which it sits. Where ring joint facings are to be applied, use dimension K as given in ASME B16.5.

ASME B16.9-2012

Table 10 Dimensions of Caps

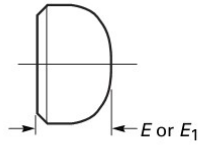

Nominal Pipe Size (NPS)	Outside Diameter at Bevel	Length, E [Note (1)]	Limiting Wall Thickness for Length, E	Length, E_1 [Note (2)]
1/2	21.3	25	4.57	25
3/4	26.7	25	3.81	25
1	33.4	38	4.57	38
1 1/4	42.2	38	4.83	38
1 1/2	48.3	38	5.08	38
2	60.3	38	5.59	44
2 1/2	73.0	38	7.11	51
3	88.9	51	7.62	64
3 1/2	101.6	64	8.13	76
4	114.3	64	8.64	76
5	141.3	76	9.65	89
6	168.3	89	10.92	102
8	219.1	102	12.70	127
10	273.0	127	12.70	152
12	323.8	152	12.70	178
14	355.6	165	12.70	191
16	406.4	178	12.70	203
18	457.0	203	12.70	229
20	508.0	229	12.70	254
22	559.0	254	12.70	254
24	610.0	267	12.70	305
26	660.0	267
28	711.0	267
30	762.0	267
32	813.0	267
34	864.0	267
36	914.0	267
38	965.0	305
40	1 016.0	305
42	1 067.0	305
44	1 118.0	343
46	1 168.0	343
48	1 219.0	343

GENERAL NOTES:

- (a) All dimensions are in millimeters.
- (b) The shape of these caps shall be ellipsoidal and shall conform to the requirements given in the ASME Boiler and Pressure Vessel Code.

NOTES:

- (1) Length E applies for thickness not exceeding that given in column "Limiting Wall Thickness for Length, E ."
- (2) Length E_1 applies for thickness greater than that given in column "Limiting Wall Thickness" for NPS 24 and smaller. For NPS 26 and larger, length E_1 shall be by agreement between the manufacturer and purchaser.

ASME B16.9-2012

Table 11 Dimensions of Reducers

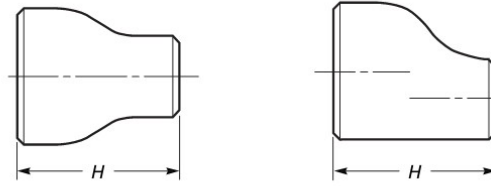

Nominal Pipe Size (NPS)	Outside Diameter at Bevel		End-to-End, H	Nominal Pipe Size (NPS)	Outside Diameter at Bevel		End-to-End, H
	Large End	Small End			Large End	Small End	
3/4 x 1/2	26.7	21.3	38	5 x 4	141.3	114.3	127
3/4 x 3/8	26.7	17.3	38	5 x 3 1/2	141.3	101.6	127
1 x 3/4	33.4	26.7	51	5 x 3	141.3	88.9	127
1 x 1/2	33.4	21.3	51	5 x 2 1/2	141.3	73.0	127
				5 x 2	141.3	60.3	127
1 1/4 x 1	42.2	33.4	51	6 x 5	168.3	141.3	140
1 1/4 x 3/4	42.2	26.7	51	6 x 4	168.3	114.3	140
1 1/4 x 1/2	42.2	21.3	51	6 x 3 1/2	168.3	101.6	140
				6 x 3	168.3	88.9	140
1 1/2 x 1 1/4	48.3	42.2	64	6 x 2 1/2	168.3	73.0	140
1 1/2 x 1	48.3	33.4	64				
1 1/2 x 3/4	48.3	26.7	64	8 x 6	219.1	168.3	152
1 1/2 x 1/2	48.3	21.3	64	8 x 5	219.1	141.3	152
				8 x 4	219.1	114.3	152
2 x 1 1/2	60.3	48.3	76	8 x 3 1/2	219.1	101.6	152
2 x 1 1/4	60.3	42.2	76				
2 x 1	60.3	33.4	76	10 x 8	273.0	219.1	178
2 x 3/4	60.3	26.7	76	10 x 6	273.0	168.3	178
				10 x 5	273.0	141.3	178
2 1/2 x 2	73.0	60.3	89	10 x 4	273.0	114.3	178
2 1/2 x 1 1/2	73.0	48.3	89				
2 1/2 x 1 1/4	73.0	42.2	89	12 x 10	323.8	273.0	203
2 1/2 x 1	73.0	33.4	89	12 x 8	323.8	219.1	203
				12 x 6	323.8	168.3	203
3 x 2 1/2	88.9	73.0	89	12 x 5	323.8	141.3	203
3 x 2	88.9	60.3	89				
3 x 1 1/2	88.9	48.3	89	14 x 12	355.6	323.8	330
3 x 1 1/4	88.9	42.2	89	14 x 10	355.6	273.0	330
				14 x 8	355.6	219.1	330
3 1/2 x 3	101.6	88.9	102	14 x 6	355.6	168.3	330
3 1/2 x 2 1/2	101.6	73.0	102				
3 1/2 x 2	101.6	60.3	102	16 x 14	406.4	355.6	356
3 1/2 x 1 1/2	101.6	48.3	102	16 x 12	406.4	323.8	356
3 1/2 x 1 1/4	101.6	42.2	102	16 x 10	406.4	273.0	356
				16 x 8	406.4	219.1	356
4 x 3 1/2	114.3	101.6	102				
4 x 3	114.3	88.9	102	18 x 16	457	406.4	381
4 x 2 1/2	114.3	73.0	102	18 x 14	457	355.6	381
4 x 2	114.3	60.3	102	18 x 12	457	323.8	381
4 x 1 1/2	114.3	48.3	102	18 x 10	457	273.0	381

ASME B16.9-2012

Table 11 Dimensions of Reducers (Cont'd)

Nominal Pipe Size (NPS)	Outside Diameter at Bevel		End-to-End, H	Nominal Pipe Size (NPS)	Outside Diameter at Bevel		End-to-End, H
	Large End	Small End			Large End	Small End	
20 × 18	508	457.0	508	36 × 34	914	864	610
20 × 16	508	406.4	508	36 × 32	914	813	610
20 × 14	508	355.6	508	36 × 30	914	762	610
20 × 12	508	323.8	508	36 × 26	914	660	610
				36 × 24	914	610	610
22 × 20	559	508.0	508				
22 × 18	559	457.0	508	38 × 36	965	914	610
22 × 16	559	406.4	508	38 × 34	965	864	610
22 × 14	559	355.4	508	38 × 32	965	813	610
				38 × 30	965	762	610
				38 × 28	965	711	610
24 × 22	610	559.0	508	38 × 26	965	660	610
24 × 20	610	508.0	508				
24 × 18	610	457.0	508	40 × 38	1 016	965	610
24 × 16	610	406.4	508	40 × 36	1 016	914	610
				40 × 34	1 016	864	610
26 × 24	660	610.0	610	40 × 32	1 016	813	610
26 × 22	660	559.0	610	40 × 30	1 016	762	610
26 × 20	660	508.0	610				
26 × 18	660	457.0	610	42 × 40	1 067	1 016	610
				42 × 38	1 067	965	610
28 × 26	711	660.0	610	42 × 36	1 067	914	610
28 × 24	711	610.0	610	42 × 34	1 067	864	610
28 × 20	711	508.0	610	42 × 32	1 067	813	610
28 × 18	711	457.0	610	42 × 30	1 067	762	610
30 × 28	762	711.0	610	44 × 42	1 118	1 067	610
30 × 26	762	660.0	610	44 × 40	1 118	1 016	610
30 × 24	762	610.0	610	44 × 38	1 118	965	610
30 × 20	762	508.0	610	44 × 36	1 118	914	610
32 × 30	813	762.0	610	46 × 44	1 168	1 118	711
32 × 28	813	711.0	610	46 × 42	1 168	1 067	711
32 × 26	813	660.0	610	46 × 40	1 168	1 016	711
32 × 24	813	610.0	610	46 × 38	1 168	965	711
34 × 32	864	813.0	610	48 × 46	1 219	1 168	711
34 × 30	864	762.0	610	48 × 44	1 219	1 118	711
34 × 26	864	660.0	610	48 × 42	1 219	1 067	711
34 × 24	864	610.0	610	48 × 40	1 219	1 016	711

GENERAL NOTES:

(a) All dimensions are in millimeters.

(b) While the figure illustrates a bell-shaped reducer, the use of a conical reducer is not prohibited.

Table 12 Welding Bevels and Root Face

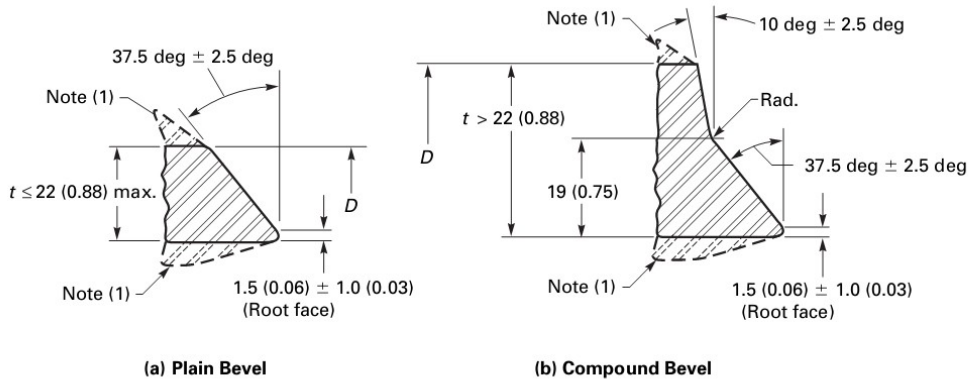

Nominal Wall Thickness, t	End Preparation
Less than x [Note (2)]	Cut square or slightly chamfer, at manufacturer's option (not illustrated)
x to 22 (0.88), inclusive	Plain bevel as in illustration (a) above
More than 22 (0.88)	Compound bevel as in illustration (b) above

GENERAL NOTES:

- (a) Dimensions in parentheses are in inches.
- (b) Other dimensions are in millimeters.

NOTES:

- (1) See section 8 and Fig. 1 for transition contours.
- (2) $x = 5$ (0.19) for carbon steel or ferritic alloy steel and 3 (0.12) for austenitic alloy steel.

Table 13 Tolerances

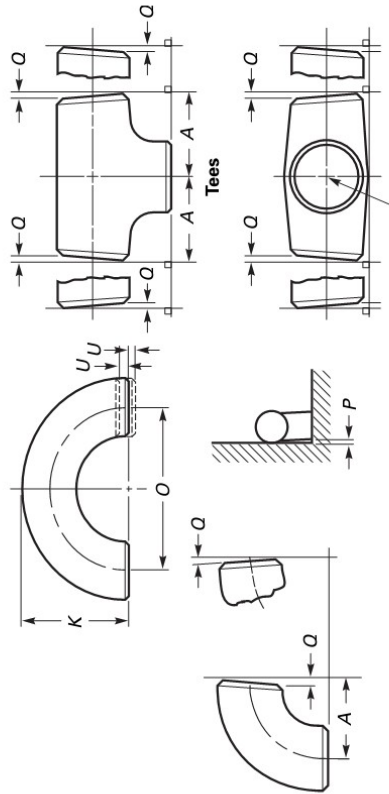

Nominal Pipe Size (NPS)	DN	All Fittings [Notes (1) and (2)]		Center-to-End Dimensions		Overall Length of Reducers and Lap Joint Stub Ends, F, H, E			Center-to-Center Dimension, O	180-deg Returns Back-to-Face Dimension, K	Alignment of Ends, U
		Outside Diameter at Bevel, D [Notes (3) and (4)]	Inside Diameter at End [Notes (3) and (5)]	90-deg and 45-deg Long and Short Radius Elbows and Tees, A, B, C, M	3D Radius Elbows, A, B	Overall Length of Reducers and Lap Joint Stub Ends, F, H, E					
1/2 to 2 1/2	15-65	+1.6, -0.8	0.8	2	3	2	3	3	6	6	1
3 to 3 1/2	80-90	1.6	1.6	2	3	2	3	3	6	6	1
4	100	1.6	1.6	2	3	2	3	3	6	6	1
5 to 8	125-200	+2.4, -1.6	1.6	2	3	2	3	6	6	6	1
10 to 18	250-450	+4.0, -3.2	3.2	2	3	2	3	6	10	6	2
20 to 24	500-600	+6.4, -4.8	4.8	2	3	2	3	6	10	6	2
26 to 30	650-750	+6.4, -4.8	4.8	3	6	5	6	10
32 to 48	800-1200	+6.4, -4.8	4.8	5	6	5	6	10

Table 13 Tolerances (Cont'd)

Nominal Pipe Size (NPS)	Lap Joint Stub Ends [Note (6)]			Nominal Pipe Size (NPS)	DN	Angularity Tolerances	
	Outside Diameter of Lap, G	Fillet Radius of Lap, R	Lap Thickness			Off Angle, Q	Off Plane, P
1/2 to 2 1/2	+0, -1	+0, -1	+1.6, -0	1/2 to 4	15-100	1	2
3 to 3 1/2	+0, -1	+0, -1	+1.6, -0	5 to 8	125-200	2	4
4	+0, -1	+0, -2	+1.6, -0	10 to 12	250-300	3	5
5 to 8	+0, -1	+0, -2	+1.6, -0	14 to 16	350-400	3	6
10 to 18	+0, -2	+0, -2	+3.2, -0	18 to 24	450-600	4	10
20 to 24	+0, -2	+0, -2	+3.2, -0	26 to 30	650-750	5	10
26 to 30	32 to 42	800-1 050	5	13
32 to 48	44 to 48	1 100-1 200	5	19

GENERAL NOTES:

(a) All dimensions are in millimeters.

(b) Tolerances are equal plus and minus except as noted.

NOTES:

(1) The inside diameter and the nominal wall thicknesses at ends are to be specified by the purchaser.

(2) A minimum wall thickness of 87.5% applies unless the purchaser specifies a different wall thickness tolerance. See Fig. 1, Note (1)(a).

(3) Out-of-round is the sum of absolute values of plus and minus tolerances.

(4) This tolerance may not apply in localized areas of formed fittings where increased wall thickness is required to meet design requirements of para. 2.2.

(5) Unless otherwise specified by the purchaser, these tolerances apply to the nominal inside diameter, which equals the difference between the nominal outside diameter and twice the nominal wall thickness.

(6) See Table 9 for limiting dimensions of outside diameter of barrel.

INTENTIONALLY LEFT BLANK

MANDATORY APPENDIX I INCH TABLES

This Mandatory Appendix provides tables of the standard inch dimensions for fittings.

ASME B16.9-2012

Table I-1 Dimensions of Long Radius Elbows

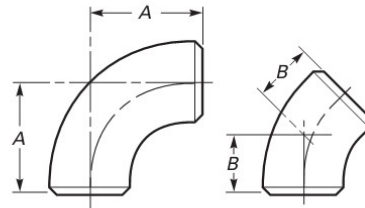

Nominal Pipe Size (NPS)	Outside Diameter at Bevel	Center-to-End	
		90-deg Elbows, A	45-deg Elbows, B
1/2	0.84	1.50	0.62
3/4	1.05	1.50	0.75
1	1.32	1.50	0.88
1 1/4	1.66	1.88	1.00
1 1/2	1.90	2.25	1.12
2	2.38	3.00	1.38
2 1/2	2.88	3.75	1.75
3	3.50	4.50	2.00
3 1/2	4.00	5.25	2.25
4	4.50	6.00	2.50
5	5.56	7.50	3.12
6	6.62	9.00	3.75
8	8.62	12.00	5.00
10	10.75	15.00	6.25
12	12.75	18.00	7.50
14	14.00	21.00	8.75
16	16.00	24.00	10.00
18	18.00	27.00	11.25
20	20.00	30.00	12.50
22	22.00	33.00	13.50
24	24.00	36.00	15.00
26	26.00	39.00	16.00
28	28.00	42.00	17.25
30	30.00	45.00	18.50
32	32.00	48.00	19.75
34	34.00	51.00	21.00
36	36.00	54.00	22.25
38	38.00	57.00	23.62
40	40.00	60.00	24.88
42	42.00	63.00	26.00
44	44.00	66.00	27.38
46	46.00	69.00	28.62
48	48.00	72.00	29.88

GENERAL NOTE: All dimensions are in inches.

ASME B16.9-2012

Table I-2 Dimensions of Long Radius Reducing Elbows

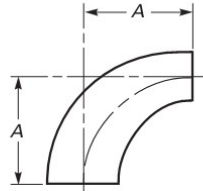

Nominal Pipe Size (NPS)	Outside Diameter at Bevel		Center-to-End, A	Nominal Pipe Size (NPS)	Outside Diameter at Bevel		Center-to-End, A
	Large End	Small End			Large End	Small End	
2 × 1½	2.38	1.90	3.00	10 × 8	10.75	8.62	15.00
2 × 1¼	2.38	1.66	3.00	10 × 6	10.75	6.62	15.00
2 × 1	2.38	1.32	3.00	10 × 5	10.75	5.56	15.00
2½ × 2	2.88	2.38	3.75	12 × 10	12.75	10.75	18.00
2½ × 1½	2.88	1.90	3.75	12 × 8	12.75	8.62	18.00
2½ × 1¼	2.88	1.66	3.75	12 × 6	12.75	6.62	18.00
3 × 2½	3.50	2.88	4.50	14 × 12	14.00	12.75	21.00
3 × 2	3.50	2.38	4.50	14 × 10	14.00	10.75	21.00
3 × 1½	3.50	1.90	4.50	14 × 8	14.00	8.62	21.00
3½ × 3	4.00	3.50	5.25	16 × 14	16.00	14.00	24.00
3½ × 2½	4.00	2.88	5.25	16 × 12	16.00	12.75	24.00
3½ × 2	4.00	2.38	5.25	16 × 10	16.00	10.75	24.00
4 × 3½	4.50	4.00	6.00	18 × 16	18.00	16.00	27.00
4 × 3	4.50	3.50	6.00	18 × 14	18.00	14.00	27.00
4 × 2½	4.50	2.88	6.00	18 × 12	18.00	12.75	27.00
4 × 2	4.50	2.38	6.00	18 × 10	18.00	10.75	27.00
5 × 4	5.56	4.50	7.50	20 × 18	20.00	18.00	30.00
5 × 3½	5.56	4.00	7.50	20 × 16	20.00	16.00	30.00
5 × 3	5.56	3.50	7.50	20 × 14	20.00	14.00	30.00
5 × 2½	5.56	2.88	7.50	20 × 12	20.00	12.75	30.00
				20 × 10	20.00	10.75	30.00
6 × 5	6.62	5.56	9.00	24 × 22	24.00	22.00	36.00
6 × 4	6.62	4.50	9.00	24 × 20	24.00	20.00	36.00
6 × 3½	6.62	4.00	9.00	24 × 18	24.00	18.00	36.00
6 × 3	6.62	3.50	9.00	24 × 16	24.00	16.00	36.00
8 × 6	8.62	6.62	12.00	24 × 14	24.00	14.00	36.00
8 × 5	8.62	5.56	12.00	24 × 12	24.00	12.75	36.00
8 × 4	8.62	4.50	12.00

GENERAL NOTE: All dimensions are in inches.

Table I-3 Dimensions of Long Radius Returns

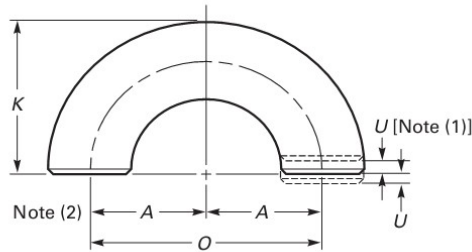

Nominal Pipe Size (NPS)	Outside Diameter at Bevel	Center-to-Center, O	Back-to-Face, K
1/2	0.84	3.00	1.88
3/4	1.05	3.00	2.00
1	1.32	3.00	2.19
1 1/4	1.66	3.75	2.75
1 1/2	1.90	4.50	3.25
2	2.38	6.00	4.19
2 1/2	2.88	7.50	5.19
3	3.50	9.00	6.25
3 1/2	4.00	10.50	7.25
4	4.50	12.00	8.25
5	5.56	15.00	10.31
6	6.62	18.00	12.31
8	8.62	24.00	16.31
10	10.75	30.00	20.38
12	12.75	36.00	24.38
14	14.00	42.00	28.00
16	16.00	48.00	32.00
18	18.00	54.00	36.00
20	20.00	60.00	40.00
22	22.00	66.00	44.00
24	24.00	72.00	48.00

GENERAL NOTE: All dimensions are in inches.

NOTES:

(1) See Table I-12 for tolerance for alignment of ends *U*.

(2) Dimension *A* is equal to one-half of dimension *O*.

Table I-4 Dimensions of Short Radius Elbows

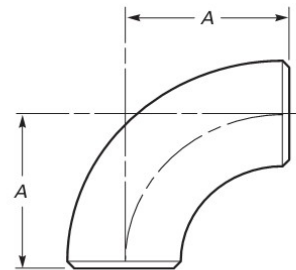

Nominal Pipe Size (NPS)	Outside Diameter at Bevel	Center-to-End, A
1	1.32	1.00
1 1/4	1.66	1.25
1 1/2	1.90	1.50
2	2.38	2.00
2 1/2	2.88	2.50
3	3.50	3.00
3 1/2	4.00	3.50
4	4.50	4.00
5	5.56	5.00
6	6.62	6.00
8	8.62	8.00
10	10.75	10.00
12	12.75	12.00
14	14.00	14.00
16	16.00	16.00
18	18.00	18.00
20	20.00	20.00
22	22.00	22.00
24	24.00	24.00

GENERAL NOTE: All dimensions are in inches.

ASME B16.9-2012

Table I-5 Dimensions of Short Radius 180-deg Returns

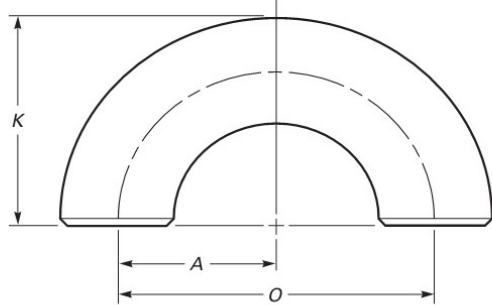

Nominal Pipe Size (NPS)	Outside Diameter at Bevel	Center-to-Center, O	Back-to-Face, K
1	1.32	2.00	1.62
1 1/4	1.66	2.50	2.06
1 1/2	1.90	3.00	2.44
2	2.38	4.00	3.19
2 1/2	2.88	5.00	3.94
3	3.50	6.00	4.75
3 1/2	4.00	7.00	5.50
4	4.50	8.00	6.25
5	5.56	10.00	7.75
6	6.62	12.00	9.31
8	8.62	16.00	12.31
10	10.75	20.00	15.38
12	12.75	24.00	18.38
14	14.00	28.00	21.00
16	16.00	32.00	24.00
18	18.00	36.00	27.00
20	20.00	40.00	30.00
22	22.00	44.00	33.00
24	24.00	48.00	36.00

GENERAL NOTES:

- (a) All dimensions are in inches.
- (b) Dimension A is equal to one-half of dimension O.

Table I-6 Dimensions of 3D Elbows

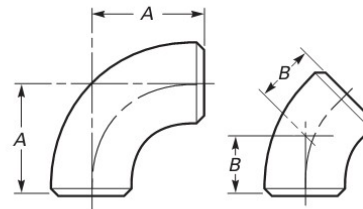

Nominal Pipe Size (NPS)	Outside Diameter at Bevel	Center-to-End	
		90-deg Elbows, A	45-deg Elbows, B
3/4	1.05	2.25	0.94
1	1.32	3.00	1.25
1 1/4	1.66	3.75	1.56
1 1/2	1.90	4.50	1.88
2	2.38	6.00	2.50
2 1/2	2.88	7.50	3.12
3	3.50	9.00	3.75
3 1/2	4.00	10.50	4.38
4	4.50	12.00	5.00
5	5.56	15.00	6.19
6	6.62	18.00	7.44
8	8.62	24.00	9.94
10	10.75	30.00	12.44
12	12.75	36.00	14.88
14	14.00	42.00	17.38
16	16.00	48.00	19.88
18	18.00	54.00	22.38
20	20.00	60.00	24.88
22	22.00	66.00	27.31
24	24.00	72.00	29.81
26	26.00	78.00	32.31
28	28.00	84.00	34.75
30	30.00	90.00	37.25
32	32.00	96.00	39.75
34	34.00	102.00	42.25
36	36.00	108.00	44.69
38	38.00	114.00	47.25
40	40.00	120.00	49.75
42	42.00	126.00	52.19
44	44.00	132.00	54.69
46	46.00	138.00	57.19
48	48.00	144.00	59.69

GENERAL NOTE: All dimensions are in inches.

ASME B16.9-2012

Table I-7 Dimensions of Straight Tees and Crosses

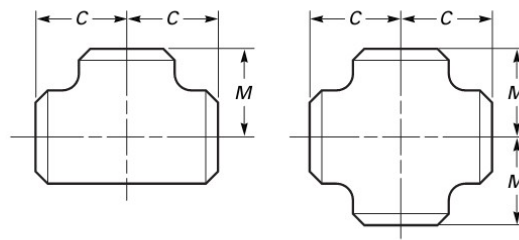

Nominal Pipe Size (NPS)	Outside Diameter at Bevel	Center-to-End	
		Run, C	Outlet, M [Notes (1) and (2)]
1/2	0.84	1.00	1.00
3/4	1.05	1.12	1.12
1	1.32	1.50	1.50
1 1/4	1.66	1.88	1.88
1 1/2	1.90	2.25	2.25
2	2.38	2.50	2.50
2 1/2	2.88	3.00	3.00
3	3.50	3.38	3.38
3 1/2	4.00	3.75	3.75
4	4.50	4.12	4.12
5	5.56	4.88	4.88
6	6.62	5.62	5.62
8	8.62	7.00	7.00
10	10.75	8.50	8.50
12	12.75	10.00	10.00
14	14.00	11.00	11.00
16	16.00	12.00	12.00
18	18.00	13.50	13.50
20	20.00	15.00	15.00
22	22.00	16.50	16.50
24	24.00	17.00	17.00
26	26.00	19.50	19.50
28	28.00	20.50	20.50
30	30.00	22.00	22.00
32	32.00	23.50	23.50
34	34.00	25.00	25.00
36	36.00	26.50	26.50
38	38.00	28.00	28.00
40	40.00	29.50	29.50
42	42.00	30.00	28.00
44	44.00	32.00	30.00
46	46.00	33.50	31.50
48	48.00	35.00	33.00

GENERAL NOTE: All dimensions are in inches.

NOTES:

- (1) Outlet dimension *M* for NPS 26 and larger is recommended but not required.
- (2) Dimensions applicable to crosses NPS 24 and smaller.

ASME B16.9-2012

Table I-8 Dimensions of Reducing Outlet Tees and Reducing Outlet Crosses

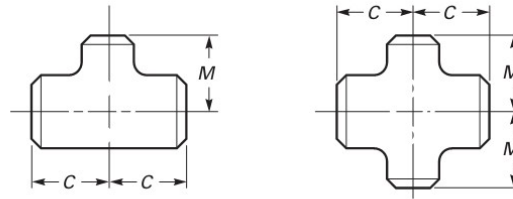

Nominal Pipe Size (NPS)	Outside Diameter at Bevel		Center-to-End		Nominal Pipe Size (NPS)	Outside Diameter at Bevel		Center-to-End	
	Run	Outlet	Run, C	Outlet, M [Note (1)]		Run	Outlet	Run, C	Outlet, M [Note (1)]
1/2 x 1/2 x 3/8	0.84	0.68	1.00	1.00	5 x 5 x 4	5.56	4.50	4.88	4.62
1/2 x 1/2 x 1/4	0.84	0.54	1.00	1.00	5 x 5 x 3 1/2	5.56	4.00	4.88	4.50
3/4 x 3/4 x 1/2	1.05	0.84	1.12	1.12	5 x 5 x 3	5.56	3.50	4.88	4.38
3/4 x 3/4 x 3/8	1.05	0.68	1.12	1.12	5 x 5 x 2 1/2	5.56	2.88	4.88	4.25
1 x 1 x 3/4	1.32	1.05	1.50	1.50	5 x 5 x 2	5.56	2.38	4.88	4.12
1 x 1 x 1/2	1.32	0.84	1.50	1.50					
					6 x 6 x 5	6.62	5.56	5.62	5.38
1 1/4 x 1 1/4 x 1	1.66	1.32	1.88	1.88	6 x 6 x 4	6.62	4.50	5.62	5.12
1 1/4 x 1 1/4 x 3/4	1.66	1.05	1.88	1.88	6 x 6 x 3 1/2	6.62	4.00	5.62	5.00
1 1/4 x 1 1/4 x 1/2	1.66	0.84	1.88	1.88	6 x 6 x 3	6.62	3.50	5.62	4.88
					6 x 6 x 2 1/2	6.62	2.88	5.62	4.75
1 1/2 x 1 1/2 x 1 1/4	1.90	1.66	2.25	2.25					
1 1/2 x 1 1/2 x 1	1.90	1.32	2.25	2.25	8 x 8 x 6	8.62	6.62	7.00	6.62
1 1/2 x 1 1/2 x 3/4	1.90	1.05	2.25	2.25	8 x 8 x 5	8.62	5.56	7.00	6.38
1 1/2 x 1 1/2 x 1/2	1.90	0.84	2.25	2.25	8 x 8 x 4	8.62	4.50	7.00	6.12
					8 x 8 x 3 1/2	8.62	4.00	7.00	6.00
2 x 2 x 1 1/2	2.38	1.90	2.50	2.38					
2 x 2 x 1 1/4	2.38	1.66	2.50	2.25	10 x 10 x 8	10.75	8.62	8.50	8.00
2 x 2 x 1	2.38	1.32	2.50	2.00	10 x 10 x 6	10.75	6.62	8.50	7.62
2 x 2 x 3/4	2.38	1.05	2.50	1.75	10 x 10 x 5	10.75	5.56	8.50	7.50
					10 x 10 x 4	10.75	4.50	8.50	7.25
2 1/2 x 2 1/2 x 2	2.88	2.38	3.00	2.75					
2 1/2 x 2 1/2 x 1 1/2	2.88	1.90	3.00	2.62	12 x 12 x 10	12.75	10.75	10.00	9.50
2 1/2 x 2 1/2 x 1 1/4	2.88	1.66	3.00	2.50	12 x 12 x 8	12.75	8.62	10.00	9.00
2 1/2 x 2 1/2 x 1	2.88	1.32	3.00	2.25	12 x 12 x 6	12.75	6.62	10.00	8.62
					12 x 12 x 5	12.75	5.56	10.00	8.50
3 x 3 x 2 1/2	3.50	2.88	3.38	3.25					
3 x 3 x 2	3.50	2.38	3.38	3.00	14 x 14 x 12	14.00	12.75	11.00	10.62
3 x 3 x 1 1/2	3.50	1.90	3.38	2.88	14 x 14 x 10	14.00	10.75	11.00	10.12
3 x 3 x 1 1/4	3.50	1.66	3.38	2.75	14 x 14 x 8	14.00	8.62	11.00	9.75
					14 x 14 x 6	14.00	6.62	11.00	9.38
3 1/2 x 3 1/2 x 3	4.00	3.50	3.75	3.62					
3 1/2 x 3 1/2 x 2 1/2	4.00	2.88	3.75	3.50	16 x 16 x 14	16.00	14.00	12.00	12.00
3 1/2 x 3 1/2 x 2	4.00	2.38	3.75	3.25	16 x 16 x 12	16.00	12.75	12.00	11.62
3 1/2 x 3 1/2 x 1 1/2	4.00	1.90	3.75	3.12	16 x 16 x 10	16.00	10.75	12.00	11.12
					16 x 16 x 8	16.00	8.62	12.00	10.75
					16 x 16 x 6	16.00	6.62	12.00	10.38
4 x 4 x 3 1/2	4.50	4.00	4.12	4.00					
4 x 4 x 3	4.50	3.50	4.12	3.88	18 x 18 x 16	18.00	16.00	13.50	13.00
4 x 4 x 2 1/2	4.50	2.88	4.12	3.75	18 x 18 x 14	18.00	14.00	13.50	13.00
4 x 4 x 2	4.50	2.38	4.12	3.50	18 x 18 x 12	18.00	12.75	13.50	12.62
4 x 4 x 1 1/2	4.50	1.90	4.12	3.38	18 x 18 x 10	18.00	10.75	13.50	12.12
					18 x 18 x 8	18.00	8.62	13.50	11.75

ASME B16.9-2012

Table I-8 Dimensions of Reducing Outlet Tees and Reducing Outlet Crosses (Cont'd)

Nominal Pipe Size (NPS)	Outside Diameter at Bevel		Center-to-End		Nominal Pipe Size (NPS)	Outside Diameter at Bevel		Center-to-End	
	Run	Outlet	Run, C	Outlet, <i>M</i> [Note (1)]		Run	Outlet	Run, C	Outlet, <i>M</i> [Note (1)]
20 × 20 × 18	20.00	18.00	15.00	14.50	30 × 30 × 18	30.00	18.00	22.00	19.50
20 × 20 × 16	20.00	16.00	15.00	14.00	30 × 30 × 16	30.00	16.00	22.00	19.00
20 × 20 × 14	20.00	14.00	15.00	14.00	30 × 30 × 14	30.00	14.00	22.00	19.00
20 × 20 × 12	20.00	12.75	15.00	13.62	30 × 30 × 12	30.00	12.75	22.00	18.62
20 × 20 × 10	20.00	10.75	15.00	13.12	30 × 30 × 10	30.00	10.75	22.00	18.12
20 × 20 × 8	20.00	8.62	15.00	12.75					
					32 × 32 × 30	32.00	30.00	23.50	23.00
22 × 22 × 20	22.00	20.00	16.50	16.00	32 × 32 × 28	32.00	28.00	23.50	22.50
22 × 22 × 18	22.00	18.00	16.50	15.50	32 × 32 × 26	32.00	26.00	23.50	22.50
22 × 22 × 16	22.00	16.00	16.50	15.00	32 × 32 × 24	32.00	24.00	23.50	22.00
22 × 22 × 14	22.00	14.00	16.50	15.00					
22 × 22 × 12	22.00	12.75	16.50	14.62	32 × 32 × 22	32.00	22.00	23.50	21.50
22 × 22 × 10	22.00	10.75	16.50	14.12	32 × 32 × 20	32.00	20.00	23.50	21.00
					32 × 32 × 18	32.00	18.00	23.50	20.50
24 × 24 × 22	24.00	22.00	17.00	17.00	32 × 32 × 16	32.00	16.00	23.50	20.00
24 × 24 × 20	24.00	20.00	17.00	17.00	32 × 32 × 14	32.00	14.00	23.50	20.00
24 × 24 × 18	24.00	18.00	17.00	16.50					
					34 × 34 × 32	34.00	32.00	25.00	24.50
24 × 24 × 16	24.00	16.00	17.00	16.00	34 × 34 × 30	34.00	30.00	25.00	24.00
24 × 24 × 14	24.00	14.00	17.00	16.00	34 × 34 × 28	34.00	28.00	25.00	23.50
24 × 24 × 12	24.00	12.75	17.00	15.62	34 × 34 × 26	34.00	26.00	25.00	23.50
24 × 24 × 10	24.00	10.75	17.00	15.12					
					34 × 34 × 24	34.00	24.00	25.00	23.00
26 × 26 × 24	26.00	24.00	19.50	19.00	34 × 34 × 22	34.00	22.00	25.00	22.50
26 × 26 × 22	26.00	22.00	19.50	18.50	34 × 34 × 20	34.00	20.00	25.00	22.00
26 × 26 × 20	26.00	20.00	19.50	18.00	34 × 34 × 18	34.00	18.00	25.00	21.50
					34 × 34 × 16	34.00	16.00	25.00	21.00
26 × 26 × 18	26.00	18.00	19.50	17.50					
26 × 26 × 16	26.00	16.00	19.50	17.00	36 × 36 × 34	36.00	34.00	26.50	26.00
26 × 26 × 14	26.00	14.00	19.50	17.00	36 × 36 × 32	36.00	32.00	26.50	25.50
26 × 26 × 12	26.00	12.75	19.50	16.62	36 × 36 × 30	36.00	30.00	26.50	25.00
					36 × 36 × 28	36.00	28.00	26.50	24.50
28 × 28 × 26	28.00	26.00	20.50	20.50	36 × 36 × 26	36.00	26.00	26.50	24.50
28 × 28 × 24	28.00	24.00	20.50	20.00					
28 × 28 × 22	28.00	22.00	20.50	19.50	36 × 36 × 24	36.00	24.00	26.50	24.00
28 × 28 × 20	28.00	20.00	20.50	19.00	36 × 36 × 22	36.00	22.00	26.50	23.50
					36 × 36 × 20	36.00	20.00	26.50	23.00
28 × 28 × 18	28.00	18.00	20.50	18.50	36 × 36 × 18	36.00	18.00	26.50	22.50
28 × 28 × 16	28.00	16.00	20.50	18.00	36 × 36 × 16	36.00	16.00	26.50	22.00
28 × 28 × 14	28.00	14.00	20.50	18.00					
28 × 28 × 12	28.00	12.75	20.50	17.62	38 × 38 × 36	38.00	36.00	28.00	28.00
					38 × 38 × 34	38.00	34.00	28.00	27.50
30 × 30 × 28	30.00	28.00	22.00	21.50	38 × 38 × 32	38.00	32.00	28.00	27.00
30 × 30 × 26	30.00	26.00	22.00	21.50	38 × 38 × 30	38.00	30.00	28.00	26.50
30 × 30 × 24	30.00	24.00	22.00	21.00	38 × 38 × 28	38.00	28.00	28.00	25.50
30 × 30 × 22	30.00	22.00	22.00	20.50					
30 × 30 × 20	30.00	20.00	22.00	20.00					

ASME B16.9-2012

Table I-8 Dimensions of Reducing Outlet Tees and Reducing Outlet Crosses (Cont'd)

Nominal Pipe Size (NPS)	Outside Diameter at Bevel		Center-to-End		Nominal Pipe Size (NPS)	Outside Diameter at Bevel		Center-to-End	
	Run	Outlet	Run, C	Outlet, <i>M</i> [Note (1)]		Run	Outlet	Run, C	Outlet, <i>M</i> [Note (1)]
38 × 38 × 26	38.00	26.00	28.00	25.50	44 × 44 × 30	44.00	30.00	32.00	28.00
38 × 38 × 24	38.00	24.00	28.00	25.00	44 × 44 × 28	44.00	28.00	32.00	27.50
38 × 38 × 22	38.00	22.00	28.00	24.50	44 × 44 × 26	44.00	26.00	32.00	27.50
38 × 38 × 20	38.00	20.00	28.00	24.00	44 × 44 × 24	44.00	24.00	32.00	27.50
38 × 38 × 18	38.00	18.00	28.00	23.50	44 × 44 × 22	44.00	22.00	32.00	27.00
					44 × 44 × 20	44.00	20.00	32.00	27.00
40 × 40 × 38	40.00	38.00	29.50	29.50					
40 × 40 × 36	40.00	36.00	29.50	29.00					
40 × 40 × 34	40.00	34.00	29.50	28.50	46 × 46 × 44	46.00	44.00	33.50	31.50
40 × 40 × 32	40.00	32.00	29.50	28.00	46 × 46 × 42	46.00	42.00	33.50	31.00
40 × 40 × 30	40.00	30.00	29.50	27.50	46 × 46 × 40	46.00	40.00	33.50	30.50
					46 × 46 × 38	46.00	38.00	33.50	30.00
40 × 40 × 28	40.00	28.00	29.50	26.50	46 × 46 × 36	46.00	36.00	33.50	30.00
40 × 40 × 26	40.00	26.00	29.50	26.50	46 × 46 × 34	46.00	34.00	33.50	29.50
40 × 40 × 24	40.00	24.00	29.50	26.00					
40 × 40 × 22	40.00	22.00	29.50	25.50					
40 × 40 × 20	40.00	20.00	29.50	25.00	46 × 46 × 32	46.00	32.00	33.50	29.50
40 × 40 × 18	40.00	18.00	29.50	24.50	46 × 46 × 30	46.00	30.00	33.50	29.00
					46 × 46 × 28	46.00	28.00	33.50	29.00
42 × 42 × 40	42.00	40.00	30.00	28.00	46 × 46 × 26	46.00	26.00	33.50	29.00
42 × 42 × 38	42.00	38.00	30.00	28.00	46 × 46 × 24	46.00	24.00	33.50	28.50
42 × 42 × 36	42.00	36.00	30.00	28.00	46 × 46 × 22	46.00	22.00	33.50	28.50
42 × 42 × 34	42.00	34.00	30.00	28.00					
42 × 42 × 32	42.00	32.00	30.00	28.00	48 × 48 × 46	48.00	46.00	35.00	33.00
42 × 42 × 30	42.00	30.00	30.00	28.00	48 × 48 × 44	48.00	44.00	35.00	33.00
42 × 42 × 28	42.00	28.00	30.00	27.50	48 × 48 × 42	48.00	42.00	35.00	32.00
42 × 42 × 26	42.00	26.00	30.00	27.50	48 × 48 × 40	48.00	40.00	35.00	32.00
42 × 42 × 24	42.00	24.00	30.00	26.00					
42 × 42 × 22	42.00	22.00	30.00	26.00	48 × 48 × 38	48.00	38.00	35.00	32.00
42 × 42 × 20	42.00	20.00	30.00	26.00	48 × 48 × 36	48.00	36.00	35.00	31.00
42 × 42 × 18	42.00	18.00	30.00	25.50	48 × 48 × 34	48.00	34.00	35.00	31.00
42 × 42 × 16	42.00	16.00	30.00	25.00	48 × 48 × 32	48.00	32.00	35.00	31.00
44 × 44 × 42	44.00	42.00	32.00	30.00					
44 × 44 × 40	44.00	40.00	32.00	29.50	48 × 48 × 30	48.00	30.00	35.00	30.00
44 × 44 × 38	44.00	38.00	32.00	29.00	48 × 48 × 28	48.00	28.00	35.00	30.00
44 × 44 × 36	44.00	36.00	32.00	28.50	48 × 48 × 26	48.00	26.00	35.00	30.00
44 × 44 × 34	44.00	34.00	32.00	28.50	48 × 48 × 24	48.00	24.00	35.00	29.00
44 × 44 × 32	44.00	32.00	32.00	28.00	48 × 48 × 22	48.00	22.00	35.00	29.00

GENERAL NOTE: All dimensions are in inches.

NOTE:

(1) Outlet dimension *M* for run sizes NPS 14 and larger is recommended but not required.

ASME B16.9-2012

Table I-9 Dimensions of Lap Joint Stub Ends

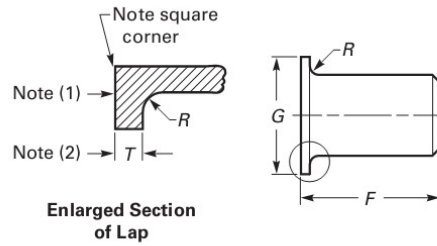

Nominal Pipe Size (NPS)	Outside Diameter of Barrel		Long Pattern Length, F [Notes (3), (4)]	Short Pattern Length, F [Notes (3), (4)]	Radius of Fillet, R [Note (5)]	Diameter of Lap, G [Note (6)]
	Max.	Min.				
1/2	0.896	0.809	3.00	2.00	0.12	1.38
3/4	1.106	1.019	3.00	2.00	0.12	1.69
1	1.376	1.284	4.00	2.00	0.12	2.00
1 1/4	1.716	1.629	4.00	2.00	0.19	2.50
1 1/2	1.965	1.869	4.00	2.00	0.25	2.88
2	2.456	2.344	6.00	2.50	0.31	3.62
2 1/2	2.966	2.844	6.00	2.50	0.31	4.12
3	3.596	3.469	6.00	2.50	0.38	5.00
3 1/2	4.096	3.969	6.00	3.00	0.38	5.50
4	4.593	4.469	6.00	3.00	0.44	6.19
5	5.683	5.532	8.00	3.00	0.44	7.31
6	6.743	6.594	8.00	3.50	0.50	8.50
8	8.743	8.594	8.00	4.00	0.50	10.62
10	10.913	10.719	10.00	5.00	0.50	12.75
12	12.913	12.719	10.00	6.00	0.50	15.00
14	14.170	13.969	12.00	6.00	0.50	16.25
16	16.180	15.969	12.00	6.00	0.50	18.50
18	18.190	17.969	12.00	6.00	0.50	21.00
20	20.240	19.969	12.00	6.00	0.50	23.00
22	22.240	21.969	12.00	6.00	0.50	25.25
24	24.240	23.969	12.00	6.00	0.50	27.25

GENERAL NOTES:

- (a) All dimensions are in inches.
- (b) See Table I-12 for tolerances.
- (c) Service conditions and joint construction often dictate stub end length requirements. Therefore, the purchaser must specify long or short pattern fitting when ordering.

NOTES:

- (1) Gasket face finish shall be in accordance with ASME B16.5 for raised face flanges.
- (2) The lap thickness, T , shall not be less than nominal pipe wall thickness. See Table I-12 for tolerance.
- (3) When short pattern stub ends are used with larger flanges in Classes 300 and 600, with most sizes in Classes 900 and higher, and when long pattern stub ends are used with larger flanges in Classes 1500 and 2500, it may be necessary to increase the length of the stub ends in order to avoid covering the weld with the flange. Such increases in length shall be a matter of agreement between the manufacturer and purchaser.
- (4) When special facings such as tongue and groove, male and female, etc., are employed, additional lap thickness must be provided and such additional thickness shall be in addition to (not included in) the basic length, F .
- (5) These dimensions conform to the radius established for lap joint flanges in ASME B16.5.
- (6) This dimension conforms to standard machined facings shown in ASME B16.5. The back face of the lap shall be machined to conform to the surface on which it sits. Where ring joint facings are to be applied, use dimension K as given in ASME B16.5.

ASME B16.9-2012

Table I-10 Dimensions of Caps

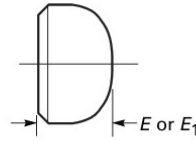

Nominal Pipe Size (NPS)	Outside Diameter at Bevel	Length, E [Note (1)]	Limiting Wall Thickness for Length, E	Length, E_1 [Note (2)]
1/2	0.84	1.00	0.18	1.00
3/4	1.05	1.00	0.15	1.00
1	1.32	1.50	0.18	1.50
1 1/4	1.66	1.50	0.19	1.50
1 1/2	1.90	1.50	0.20	1.50
2	2.38	1.50	0.22	1.75
2 1/2	2.88	1.50	0.28	2.00
3	3.50	2.00	0.30	2.50
3 1/2	4.00	2.50	0.32	3.00
4	4.50	2.50	0.34	3.00
5	5.56	3.00	0.38	3.50
6	6.62	3.50	0.43	4.00
8	8.62	4.00	0.50	5.00
10	10.75	5.00	0.50	6.00
12	12.75	6.00	0.50	7.00
14	14.00	6.50	0.50	7.50
16	16.00	7.00	0.50	8.00
18	18.00	8.00	0.50	9.00
20	20.00	9.00	0.50	10.00
22	22.00	10.00	0.50	10.00
24	24.00	10.50	0.50	12.00
26	26.00	10.50
28	28.00	10.50
30	30.00	10.50
32	32.00	10.50
34	34.00	10.50
36	36.00	10.50
38	38.00	12.00
40	40.00	12.00
42	42.00	12.00
44	44.00	13.50
46	46.00	13.50
48	48.00	13.50

GENERAL NOTES:

- (a) All dimensions are in inches.
 (b) The shape of these caps shall be ellipsoidal and shall conform to the requirements given in the ASME Boiler and Pressure Vessel Code.

NOTES:

- (1) Length E applies for thickness not exceeding that given in column "Limiting Wall Thickness for Length, E ."
 (2) Length E_1 applies for thickness greater than that given in column "Limiting Wall Thickness" for NPS 24 and smaller. For NPS 26 and larger, length E_1 shall be by agreement between the manufacturer and purchaser.

ASME B16.9-2012

Table I-11 Dimensions of Reducers

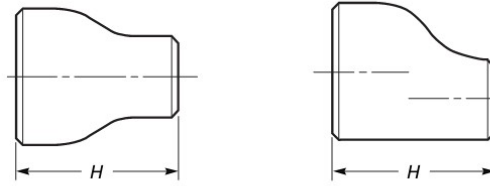

Nominal Pipe Size (NPS)	Outside Diameter at Bevel		End-to-End, H	Nominal Pipe Size (NPS)	Outside Diameter at Bevel		End-to-End, H
	Large End	Small End			Large End	Small End	
3/4 x 1/2	1.05	0.84	1.50	5 x 4	5.56	4.50	5.00
3/4 x 3/8	1.05	0.68	1.50	5 x 3 1/2	5.56	4.00	5.00
1 x 3/4	1.32	1.05	2.00	5 x 3	5.56	3.50	5.00
1 x 1/2	1.32	0.84	2.00	5 x 2 1/2	5.56	2.88	5.00
				5 x 2	5.56	2.38	5.00
1 1/4 x 1	1.66	1.32	2.00	6 x 5	6.62	5.56	5.50
1 1/4 x 3/4	1.66	1.05	2.00	6 x 4	6.62	4.50	5.50
1 1/4 x 1/2	1.66	0.84	2.00	6 x 3 1/2	6.62	4.00	5.50
1 1/2 x 1 1/4	1.90	1.66	2.50	6 x 3	6.62	3.50	5.50
1 1/2 x 1	1.90	1.32	2.50	6 x 2 1/2	6.62	2.88	5.50
1 1/2 x 3/4	1.90	1.05	2.50	8 x 6	8.62	6.62	6.00
1 1/2 x 1/2	1.90	0.84	2.50	8 x 5	8.62	5.56	6.00
2 x 1 1/2	2.38	1.90	3.00	8 x 4	8.62	4.50	6.00
2 x 1 1/4	2.38	1.66	3.00	8 x 3 1/2	8.62	4.00	6.00
2 x 1	2.38	1.32	3.00	10 x 8	10.75	8.62	7.00
2 x 3/4	2.38	1.05	3.00	10 x 6	10.75	6.62	7.00
2 1/2 x 2	2.88	2.38	3.50	10 x 5	10.75	5.56	7.00
2 1/2 x 1 1/2	2.88	1.90	3.50	10 x 4	10.75	4.50	7.00
2 1/2 x 1 1/4	2.88	1.66	3.50	12 x 10	12.75	10.75	8.00
2 1/2 x 1	2.88	1.32	3.50	12 x 8	12.75	8.62	8.00
3 x 2 1/2	3.50	2.88	3.50	12 x 6	12.75	6.62	8.00
3 x 2	3.50	2.38	3.50	12 x 5	12.75	5.56	8.00
3 x 1 1/2	3.50	1.90	3.50	14 x 12	14.00	12.75	13.00
3 x 1 1/4	3.50	1.66	3.50	14 x 10	14.00	10.75	13.00
3 1/2 x 3	4.00	3.50	4.00	14 x 8	14.00	8.62	13.00
3 1/2 x 2 1/2	4.00	2.88	4.00	14 x 6	14.00	6.62	13.00
3 1/2 x 2	4.00	2.38	4.00	16 x 14	16.00	14.00	14.00
3 1/2 x 1 1/2	4.00	1.90	4.00	16 x 12	16.00	12.75	14.00
3 1/2 x 1 1/4	4.00	1.66	4.00	16 x 10	16.00	10.75	14.00
				16 x 8	16.00	8.62	14.00
4 x 3 1/2	4.50	4.00	4.00	18 x 16	18.00	16.00	15.00
4 x 3	4.50	3.50	4.00	18 x 14	18.00	14.00	15.00
4 x 2 1/2	4.50	2.88	4.00	18 x 12	18.00	12.75	15.00
4 x 2	4.50	2.38	4.00	18 x 10	18.00	10.75	15.00
4 x 1 1/2	4.50	1.90	4.00				

ASME B16.9-2012

Table I-11 Dimensions of Reducers (Cont'd)

Nominal Pipe Size (NPS)	Outside Diameter at Bevel		End-to-End, H	Nominal Pipe Size (NPS)	Outside Diameter at Bevel		End-to-End, H
	Large End	Small End			Large End	Small End	
20 × 18	20.00	18.00	20.00	36 × 34	36.00	34.00	24.00
20 × 16	20.00	16.00	20.00	36 × 32	36.00	32.00	24.00
20 × 14	20.00	14.00	20.00	36 × 30	36.00	30.00	24.00
20 × 12	20.00	12.75	20.00	36 × 26	36.00	26.00	24.00
				36 × 24	36.00	24.00	24.00
22 × 20	22.00	20.00	20.00				
22 × 18	22.00	18.00	20.00	38 × 36	38.00	36.00	24.00
22 × 16	22.00	16.00	20.00	38 × 34	38.00	34.00	24.00
22 × 14	22.00	14.00	20.00	38 × 32	38.00	32.00	24.00
				38 × 30	38.00	30.00	24.00
24 × 22	24.00	22.00	20.00	38 × 28	38.00	28.00	24.00
24 × 20	24.00	20.00	20.00	38 × 26	38.00	26.00	24.00
24 × 18	24.00	18.00	20.00				
24 × 16	24.00	16.00	20.00	40 × 38	40.00	38.00	24.00
				40 × 36	40.00	36.00	24.00
26 × 24	26.00	24.00	24.00	40 × 34	40.00	34.00	24.00
26 × 22	26.00	22.00	24.00	40 × 32	40.00	32.00	24.00
26 × 20	26.00	20.00	24.00	40 × 30	40.00	30.00	24.00
26 × 18	26.00	18.00	24.00				
				42 × 40	42.00	40.00	24.00
28 × 26	28.00	26.00	24.00	42 × 38	42.00	38.00	24.00
28 × 24	28.00	24.00	24.00	42 × 36	42.00	36.00	24.00
28 × 20	28.00	20.00	24.00	42 × 34	42.00	34.00	24.00
28 × 18	28.00	18.00	24.00	42 × 32	42.00	32.00	24.00
				42 × 30	42.00	30.00	24.00
30 × 28	30.00	28.00	24.00				
30 × 26	30.00	26.00	24.00	44 × 42	44.00	42.00	24.00
30 × 24	30.00	24.00	24.00	44 × 40	44.00	40.00	24.00
30 × 20	30.00	20.00	24.00	44 × 38	44.00	38.00	24.00
				44 × 36	44.00	36.00	24.00
32 × 30	32.00	30.00	24.00				
32 × 28	32.00	28.00	24.00	46 × 44	46.00	44.00	28.00
32 × 26	32.00	26.00	24.00	46 × 42	46.00	42.00	28.00
32 × 24	32.00	24.00	24.00	46 × 40	46.00	40.00	28.00
				46 × 38	46.00	38.00	28.00
34 × 32	34.00	32.00	24.00				
34 × 30	34.00	30.00	24.00	48 × 46	48.00	46.00	28.00
34 × 26	34.00	26.00	24.00	48 × 44	48.00	44.00	28.00
34 × 24	34.00	24.00	24.00	48 × 42	48.00	42.00	28.00
				48 × 40	48.00	40.00	28.00

GENERAL NOTES:

(a) All dimensions are in inches.

(b) While the figure illustrates a bell-shaped reducer, the use of a conical reducer is not prohibited.

Table I-12 Tolerances

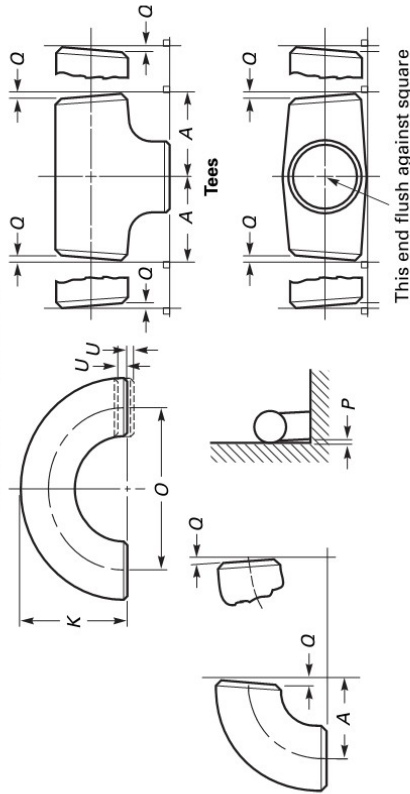

Nominal Pipe Size (NPS)	All Fittings [Notes (1) and (2)]		Center-to-End Dimensions		Overall Length of Reducers and Lap Joint Stub Ends, F, H		180-deg Returns			Lap Joint Stub Ends [Note (6)]			Angularity Tolerances	
	Outside Diameter at Bevel, D [Notes (3) and (4)]	Inside Diameter at End [Notes (3) and (5)]	90-deg and 45-deg Long and Short Radius Elbows and Tees, A, B, C, M	Center-to-Center Dimension, O	Overall Length of Caps, E	Center-to-Face Dimension, K	Back-to-Back Alignment of Ends, U	Outside Diameter of Lap, G	Fillet Radius of Lap, R	Lap Thickness, T	Off Angle, Plane, Q	Off Plane, P	Nominal Pipe Size (NPS)	Q
1/2 to 2 1/2	+0.06, -0.03	0.03	0.06	0.09	0.06	0.12	0.25	0.03	+0, -0.03	+0.06, -0	0.03	1/2 to 4	0.03	0.06
3 to 3 1/2	0.06	0.06	0.06	0.09	0.06	0.12	0.25	0.03	+0, -0.03	+0.06, -0	0.06	5 to 8	0.06	0.12
4	0.06	0.06	0.06	0.09	0.06	0.12	0.25	0.03	+0, -0.03	+0.06, -0	0.09	10 to 12	0.09	0.19
5 to 8	+0.09, -0.06	0.06	0.06	0.09	0.06	0.25	0.25	0.03	+0, -0.03	+0.06, -0	0.09	14 to 16	0.09	0.25
10 to 18	+0.16, -0.12	0.12	0.09	0.12	0.09	0.25	0.38	0.06	+0, -0.06	+0.12, -0	0.12	18 to 24	0.12	0.38
20 to 24	+0.25, -0.19	0.19	0.09	0.12	0.09	0.25	0.38	0.06	+0, -0.06	+0.12, -0	0.19	26 to 30	0.19	0.38
26 to 30	+0.25, -0.19	0.19	0.12	0.25	0.19	0.38	32 to 42	0.19	0.50
32 to 48	+0.25, -0.19	0.19	0.19	0.38	0.19	0.38	44 to 48	0.19	0.75

GENERAL NOTES:

- (a) All dimensions are in inches.
- (b) Tolerances are equal plus and minus except as noted.

NOTES:

- (1) The inside diameter and the nominal wall thicknesses at ends are to be specified by the purchaser.
- (2) A minimum wall thickness of 87.5% applies unless the purchaser specifies a different wall thickness tolerance. See Fig. 1, Note (1)(a).
- (3) Out-of-round is the sum of absolute values of plus and minus tolerances.
- (4) This tolerance may not apply in localized areas of formed fittings where increased wall thickness is required to meet design requirements of para. 2.2.
- (5) Unless otherwise specified by the purchaser, these tolerances apply to the nominal inside diameter, which equals the difference between the nominal outside diameter and twice the nominal wall thickness.
- (6) See Table I-9 for limiting dimensions of outside diameter of barrel.

MANDATORY APPENDIX II REFERENCES

(12)

The following is a list of standards and specifications referenced in this Standard. Unless otherwise specified, the latest edition of ASME publications shall apply.

- ASME B16.5, Pipe Flanges and Flanged Fittings: NPS ½ Through NPS 24 Metric/Inch Standard
- ASME B16.25, Buttwelding Ends
- ASME B16.49, Factory-Made Wrought Steel Buttwelding Induction Bends for Transportation and Distribution Systems
- ASME B31, Code for Pressure Piping
- ASME B36.10M, Welded and Seamless Wrought Steel Pipe
- ASME B36.19M, Stainless Steel Pipe
- ASME Boiler and Pressure Vessel Code
- Publisher: The American Society of Mechanical Engineers (ASME), Two Park Avenue, New York, NY 10016-5990; Order Department: 22 Law Drive, P.O. Box 2900, Fairfield, NJ 07007-2900 (www.asme.org)
- ASTM A234/A234M-11a, Specification for Piping Fittings of Wrought Carbon Steel and Alloy Steel for Moderate and High Temperature Service
- ASTM A403/A403M-11, Specification for Wrought Austenitic Stainless Steel Piping Fittings
- ASTM A420/A420M-10a, Specification for Piping Fittings of Wrought Carbon Steel and Alloy Steel for Low-Temperature Service
- ASTM A815/A815M-10a, Specification for Wrought Ferritic, Ferritic/Austenitic and Martensitic Stainless Steel Piping Fittings
- ASTM A960/A960M-10, Specification for Common Requirements for Wrought Steel Piping Fittings
- ASTM B361-08, Specification for Factory-Made Wrought Aluminum and Aluminum-Alloy Welding Fittings
- ASTM B363-06a, Specification for Seamless and Welded Unalloyed Titanium and Titanium Alloy Welding Fittings
- ASTM B366-10a, Specification for Factory-Made Wrought Nickel and Nickel Alloy Fittings
- ASTM E29-08, Practice for Using Significant Digits in Test Data to Determine Conformance With Specifications
- Publisher: American Society for Testing and Materials (ASTM International), 100 Barr Harbor Drive, P.O. Box C700, West Conshohocken, PA 19428-2959 (www.astm.org)
- ISO 6708:1995, Pipework components — Definition and selection of DN (nominal size)
- ISO 9000:2005, Quality management systems — Fundamentals and vocabulary
- ISO 9001:2008, Quality management systems — Requirements
- ISO 9004:2009, Managing for the sustained success of an organization — A quality management approach
- Publisher: International Organization for Standardization (ISO Central Secretariat), 1, ch. de la Voie-Creuse, CP 56, CH-1211, Geneva 20, Switzerland (www.iso.org)

NONMANDATORY APPENDIX A QUALITY SYSTEM PROGRAM

The products manufactured in accordance with this Standard shall be produced under a Quality System Program following the principles of an appropriate standard from the ISO 9000 series.¹ A determination of the need for registration and/or certification of the product

¹ The series is also available from the American National Standards Institute (ANSI) and the American Society for Quality (ASQ) as American National Standards that are identified by the prefix "Q," replacing the prefix "ISO." Each standard of the series is listed under References in Mandatory Appendix II.

manufacturer's quality system by an independent organization shall be the responsibility of the manufacturer. The detailed documentation demonstrating program compliance shall be available to the purchaser at the manufacturer's facility. A written summary description of the program utilized by the product manufacturer shall be available to the purchaser upon request. The *product manufacturer* is defined as the entity whose name or trademark appears on the product in accordance with the marking or identification requirements of this Standard.

B16 AMERICAN NATIONAL STANDARDS FOR PIPING, PIPE FLANGES, FITTINGS, AND VALVES

Gray Iron Pipe Flanges and Flanged Fittings (Classes 25, 125, and 250)	B16.1-2010
Malleable Iron Threaded Fittings: Classes 150 and 300	B16.3-2011
Gray Iron Threaded Fittings: Classes 125 and 250	B16.4-2011
Pipe Flanges and Flanged Fittings NPS ½ Through NPS 24 Metric/Inch Standard	B16.5-2009
Factory-Made Wrought Butt welding Fittings	B16.9-2012
Face-to-Face and End-to-End Dimensions of Valves	B16.10-2009
Forged Fittings, Socket-Welding and Threaded	B16.11-2011
Cast Iron Threaded Drainage Fittings	B16.12-2009
Ferrous Pipe Plugs, Bushings, and Locknuts with Pipe Threads	B16.14-2010
Cast Copper Alloy Threaded Fittings	B16.15-2011
Cast Copper Alloy Solder Joint Pressure Fittings	B16.18-2012
Metallic Gaskets for Pipe Flanges: Ring-Joint, Spiral-Wound, and Jacketed	B16.20-2007
Nonmetallic Flat Gaskets for Pipe Flanges	B16.21-2005
Wrought Copper and Copper Alloy Solder-Joint Pressure Fittings	B16.22-2012
Cast Copper Alloy Solder Joint Drainage Fittings: DWV	B16.23-2011
Cast Copper Alloy Pipe Flanges and Flanged Fittings: Classes 150, 300, 600, 900, 1500, and 2500	B16.24-2011
Butt welding Ends	B16.25-2012
Cast Copper Alloy Fittings for Flared Copper Tubes	B16.26-2011
Wrought Copper and Wrought Copper Alloy Solder-Joint Drainage Fittings — DWV	B16.29-2012
Manually Operated Metallic Gas Valves for Use in Gas Piping Systems Up to 125 psi (Sizes NPS ½ Through NPS 2)	B16.33-2012
Valves — Flanged, Threaded, and Welding End	B16.34-2012
Orifice Flanges	B16.36-2009
Large Metallic Valves for Gas Distribution: Manually Operated, NPS 2½ (DN 65) to NPS 12 (DN 300), 125 psig (8.6 bar) Maximum	B16.38-2012
Malleable Iron Threaded Pipe Unions: Classes 150, 250, and 300	B16.39-2009
Manually Operated Thermoplastic Gas Shutoffs and Valves in Gas Distribution Systems	B16.40-2008
Ductile Iron Pipe Flanges and Flanged Fittings: Classes 150 and 300	B16.42-2011
Manually Operated Metallic Gas Valves for Use in Aboveground Piping Systems Up to 5 psi	B16.44-2012
Cast Iron Fittings for Solvent® Drainage Systems	B16.45-1998 (R2006)
Large Diameter Steel Flanges NPS 26 Through NPS 60 Metric/Inch Standard	B16.47-2011
Line Blanks	B16.48-2010
Factory-Made Wrought Steel Butt welding Induction Bends for Transportation and Distribution Systems	B16.49-2012
Wrought Copper and Copper Alloy Braze-Joint Pressure Fittings	B16.50-2001 (R2008)
Copper and Copper Alloy Press-Connect Pressure Fittings	B16.51-2011

The ASME Publications Catalog shows a complete list of all the Standards published by the Society. For a complimentary catalog, or the latest information about our publications, call 1-800-THE-ASME (1-800-843-2763).

ASME Services

ASME is committed to developing and delivering technical information. At ASME's Customer Care, we make every effort to answer your questions and expedite your orders. Our representatives are ready to assist you in the following areas:

ASME Press
Codes & Standards
Credit Card Orders
IMEchE Publications
Meetings & Conferences
Member Dues Status

Member Services & Benefits
Other ASME Programs
Payment Inquiries
Professional Development
Short Courses
Publications

Public Information
Self-Study Courses
Shipping Information
Subscriptions/Journals/Magazines
Symposia Volumes
Technical Papers

How can you reach us? It's easier than ever!

There are four options for making inquiries* or placing orders. Simply mail, phone, fax, or E-mail us and a Customer Care representative will handle your request.

Mail
ASME
22 Law Drive, Box 2900
Fairfield, New Jersey
07007-2900

Call Toll Free
US & Canada: 800-THE-ASME
(800-843-2763)
Mexico: 95-800-THE-ASME
(95-800-843-2763)
Universal: 973-882-1167

Fax—24 hours
973-882-1717
973-882-5155

E-Mail—24 hours
customercare@asme.org

* Customer Care staff are not permitted to answer inquiries about the technical content of this code or standard. Information as to whether or not technical inquiries are issued to this code or standard is shown on the copyright page. All technical inquiries must be submitted in writing to the staff secretary. Additional procedures for inquiries may be listed within.

INTENTIONALLY LEFT BLANK

ASME B16.9-2012

ISBN 978-0-7918-3494-7



9 780791 834947



J10912